

Spare Parts List
Ersatzteilliste
Liste de pièces détachées
Lista de piezas de repuesto

2013-05

MS-4300.4 U

DOLMAR



A member of the *Makita* Group

MS-4300.4 U (D, GB, F, E)

MS-4300.4 U

1

Hauptrohr, Griff, Schutzhaube, Getriebegehäuse
Pipe, handle, protector, gear case
Tube, poignée, capot de protection, carter d.engrenages
Tubo, mango, cubierta protectora, caja de engranajes

DOLMAR
A member of the *Makita* Group

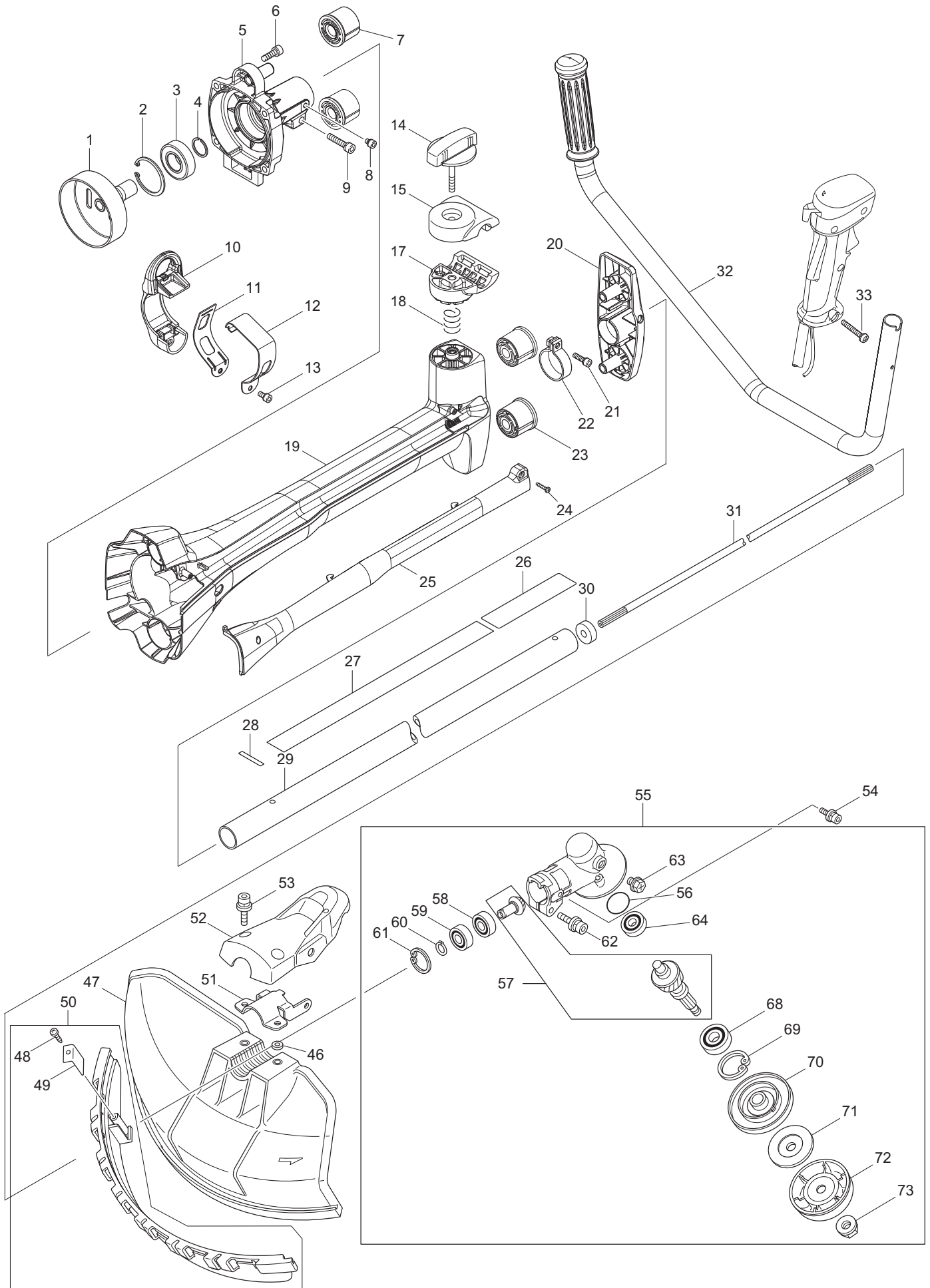

MS-4300.4 U

1

Hauptrohr, Griff, Schutzhaube, Getriebegehäuse
 Pipe, handle, protector, gear case
 Tube, poignée, capot de protection, carter d. engrenages
 Tubo, mango, cubierta protectora, caja de engranajes

DOLMAR

Seite / Page	Pos.	MS-4300.4 U	Teil-Nr. Part No. No. de pièce No. de pieza	Hinweise Notes Renseign. Nota	Bezeichnung	Spezifikation Specification	Description	Désignation	Denominación
1	1	1	367 168 712		KUPPLUNGSTROMMEL		CLUTCH DRUM	TAMBOUR	TAMBOR
1	2	1	660 962 201		SICHERUNGSRING	(INT) R-42	RETAINING RING	CIRCLIP	ANILLO SEGURIDAD
1	3	1	367 211 387		KUGELLAGER	6004LLU	BALL BEARING	ROULEMENT À BILLES	RODAMIENTO DE BOLAS
1	4	1	367 961 090		SICHERUNGSRING	(EXT) WR-20	RETAINING RING	CIRCLIP	ANILLO SEGURIDAD
1	5	1	367 318 849		KUPPLUNGSGEHÄUSE		CLUTCH CASE	CARTER D' EMBRAYAGE	CÁRTER DE EMBRAGUE
1	6	4	367 922 331		SCHRAUBE	M6X20	HEX. SOCKET HEAD BOLT	VIS HEXAGONAL	TORNILLO HEXAGONAL
1	7	2	367 424 488		SCHWINGUNGSDÄMPFER		BUFFER RUBBER	AMORTISSEUR	AMORTIGUADOR
1	8	1	367 922 201		6KT-SCHRAUBE	M5X8	HEX. SOCKET HEAD BOLT	VIS HEXAGONAL	TORNILLO HEXAGONAL
1	9	1	367 922 351		6KT-SCHRAUBE	M6X30	HEX. SOCKET HEAD BOLT	VIS HEXAGONAL	TORNILLO HEXAGONAL
1	10	1	367 453 525		TRAGEGURTAUFNAHME		HANGER	ATTACHE DE BRETTELLE	SUJECIÓN
1	11	1	367 346 572		SHELLE	L	HANGER HOLDER	BRIDE DE FIXATION	ABRAZADERA
1	12	1	367 346 571		SHELLE	R	HANGER HOLDER	BRIDE DE FIXATION	ABRAZADERA
1	13	1	367 265 991		6KT-SCHRAUBE		HEX. SOCKET HEAD BOLT	VIS HEXAGONAL	TORNILLO HEXAGONAL
1	14	1	367 168 796		KNOPF	57	KNOB	BOUTON	BOTÓN
1	15	1	367 318 425		KLEMMSCHALE		HANDLE CLAMP	DISP. DE SERRAGE	SOPORTE PRESOR
1	17	1	367 318 860		KLEMMSCHALE		HANDLE CLAMP	DISP. DE SERRAGE	SOPORTE PRESOR
1	18	1	367 233 309		DRUCKFEDER	17	COMPRESSION SPRING	RESSORT DE PRESSION	RESORTE DE PRESIÓN
1	19	1	367 453 541		GRIFFANBINDUNG	DOLMAR	PIPE HOUSING	BRIDE DE POIGNÉE	FIJACIÓN DE MANGO
1	20	1	367 453 543		KLEMMSTÜCK	DOLMAR	CLAMPING PIECE	PIÈCE INTERCALAIRE	RETEN
1	21	1	367 922 226		SCHRAUBE	M5X18	HEX. SOCKET HEAD BOLT	VIS HEXAGONAL	TORNILLO HEXAGONAL
1	22	1	367 346 590		KLEMMSCHELLE	33	PIPE CLAMP	COLLIER DE SERRAGE	ABRAZADERA DE SUJECIÓN
1	23	2	367 424 488		SCHWINGUNGSDÄMPFER		BUFFER RUBBER	AMORTISSEUR	AMORTIGUADOR
1	24	2	660 266 429		SCHNEIDSCHRAUBE	3X16	TAPPING SCREW	VIS TARAUDEUSE	TORNILLO DE ROSCA CORTANTE
1	25	1	367 453 542		ABDECKUNG	DOLMAR	HOUSING COVER	COUVERCLE	CUBIERTA
1	26	1	660 893 388		SCHILD	DOLMAR LOGO	LABEL	PLAQUE	CALCOMANIA
1	27	1	367 898 810		SICHERHEITSAUFKLEBER		CAUTION LABEL	PLAQUE	CALCOMANIA
1	28	1			SCHILD	SERIAL NO.	LABEL	PLAQUE	CALCOMANIA
1	29	1	367 141 335		SCHAFTROHR KPL.		SHAFT PIPE COMPLETE	TUBE PRINCIPAL CPL.	TUBO PRINCIPAL CPL.
1	30	1	367 443 146		FILZRING	8	FELT RING	JOINT FEUTRE	JUNTA FIELTRO
1	31	1	367 326 153		WELLE		SHAFT	ARBRE	ÁRBOL
1	32	1	367 141 584		GRIFFROHR KPL.		HANDLE COMPLETE	TUBE DE POIGNÉE CPL.	TUBO DE MANGO CPL.
1	33	1	660 911 256		FLACHKOPFSCHRAUBE	M5X35	PAN HEAD SCREW	VIS À TÊTE CYLINDRIQUE	TORNILLO DE CABEZA PLANA
1	46	2	367 413 143		SCHEIBE		WASHER	RONDELLE	ARANDELA
1	47	1	367 452 259		SCHUTZHAUBE	2010 =>	PROTECTOR	CAPOT DE PROTECTION	CUBIERTA PROTECTORA
1	48	1	660 266 326		SCHNEIDSCHRAUBE	4X18	SCREW	VIS	TORNILLO
1	49	1	367 346 074		FADENMESSER		LINE CUTTER	COUTEAU DE FIL	CUCHILLA DE HILOS
1	50	1	367 135 398		SCHUTZLEISTE KPL.	2010 =>	PROTECTOR EXTENSION ASSY	BARRE DE PROTECTION CPL.	BARRA DE PROTECCIÓN CPL.
1	51	1	367 346 072		SHELLE FÜR SCHUTZHAUBE		PROTECTOR CLAMP	COLLIER	ABRAZADERA
1	52	1	367 451 090		ABDECKUNG		PROTECTOR COVER	COUVERCLE	CUBIERTA
1	53	2	367 266 579		6KT-SCHRAUBE	M6x30	HEX. SOCKET HEAD BOLT	VIS HEXAGONAL	TORNILLO HEXAGONAL
1	54	2	367 266 865		SCHRAUBE	M5X14	H.S.H.BOLT WITH WR	VIS	TORNILLO

MS-4300.4 U

1

Hauptrohr, Griff, Schutzhaube, Getriebegehäuse
Pipe, handle, protector, gear case
Tube, poignée, capot de protection, carter d.engrenages
Tubo, mango, cubierta protectora, caja de engranajes

DOLMAR
A member of the *Makita* Group

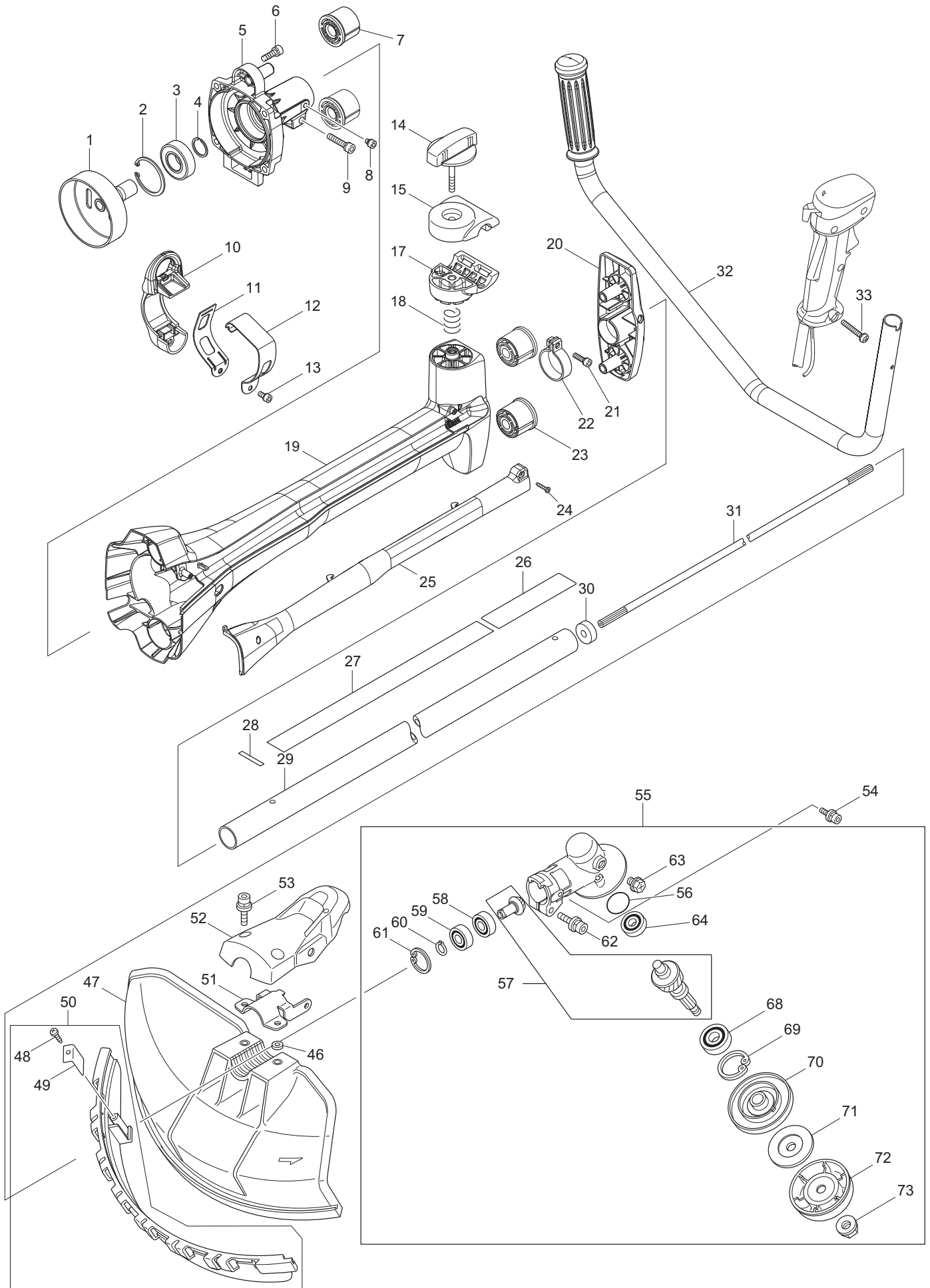

MS-4300.4 U

1

Hauptrohr, Griff, Schutzhaube, Getriebegehäuse

Pipe, handle, protector, gear case

Tube, poignée, capot de protection, carter d.engrenages

Tubo, mango, cubierta protectora, caja de engranajes

DOLMARA member of the *Makita* Group

Seite / Page	Pos.	MS-4300.4 U	Teil-Nr. Part No. No. de pièce No. de pieza	Hinweise Notes Renseign. Nota	Bezeichnung	Spezifikation Specification	Description	Désignation	Denominación
1	55	1	367 126 260		GETRIEBEGEHÄUSE KPL.		GEAR CASE ASS'Y	CARTER D'ENGRENAGES CPL.	CAJA DE ENGRANAJES CPL.
1	56	1	367 213 459		O-RING	32	O-RING	JOINT TORIQUE	ANILLO DE GUARNICIÓN
1	57	1	367 188 865		GETRIEBERÄDER KPL.		CUTTER SHAFT SET	ROUES D'ENGRENAGES CPL.	RUEDAS DE ENGRANAJE CPL.
1	58	1	367 211 064		KUGELLAGER	6000	BALL BEARING	ROULEMENT À BILLES	RODAMIENTO DE BOLAS
1	59	1	960 101 104		RILLENKUGELLAGER	6000 2Z	BALL BEARING	ROULEMENT À BILLES	RODAMIENTO DE BOLAS
1	60	1	367 961 006		SICHERUNGSRING	S-10	RETAINING RING	CIRCLIP	ANILLO SEGURIDAD
1	61	1	367 962 105		SICHERUNGSRING	R-26	RETAINING RING	CIRCLIP	ANILLO SEGURIDAD
1	62	1	367 922 353		SCHRAUBE	M6X30	HEX. SOCKET HEAD BOLT	VIS HEXAGONAL	TORNILLO HEXAGONAL
1	63	1	367 265 590		SCHRAUBE	M8X10	+HEX.BOLT WITH R	VIS HEXAGONAL	TORNILLO HEXAGONAL
1	64	1	367 210 081		KUGELLAGER	629ZZ	BALL BEARING	ROULEMENT À BILLES	RODAMIENTO DE BOLAS
1	68	1	367 210 116		KUGELLAGER	6201LLU	BALL BEARING	ROULEMENT À BILLES	RODAMIENTO DE BOLAS
1	69	1	367 962 151		SICHERUNGSRING	R-32	RETAINING RING	CIRCLIP	ANILLO SEGURIDAD
1	70	1	367 331 860		AUFNAHMESCHEIBE	ø 25,4	RECEIVE WASHER	DISQUE DE SUPPORT	DISCO DE SUJECIÓN
1	71	1	367 346 355		DRUCKSCHEIBE		CLAMP WASHER	DISQUE DE PRESSION	DISCO DE PRESION
1	72	1	367 168 526		GLEITTELLER		SLIDING CUP	BOL DE GLISSEMENT	PLATO DESLIZANTE
1	73	1	367 264 025		SECHSKANTMUTTER	M10-17	HEX NUT	ECROU HEXAGONAL	TUERCA HEXAGONAL

74

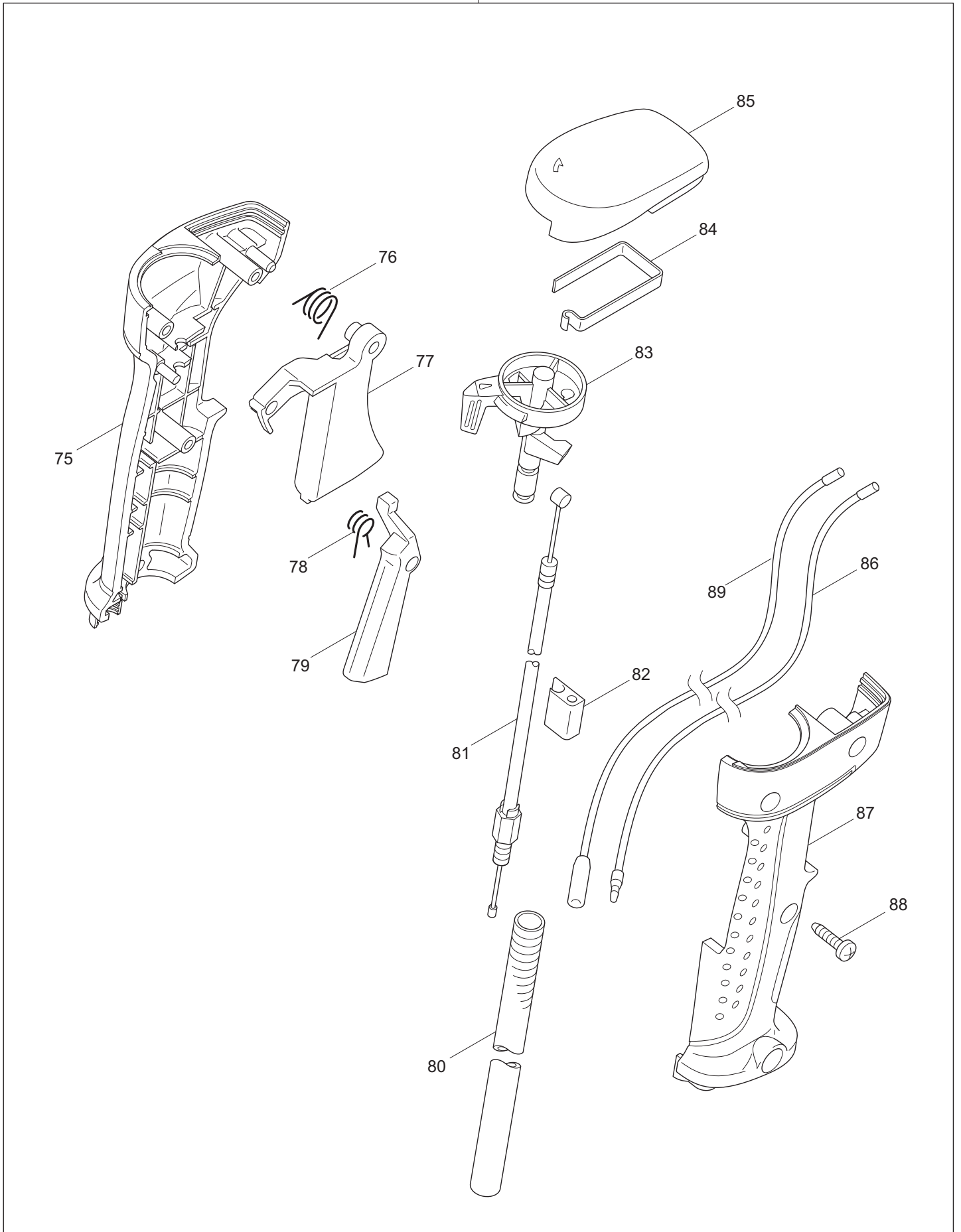

MS-4300.4 U

2

Bedienungshandgriff kpl.
Control lever ass'y
Levier de réglage, cpl.
Botón de mando, cpl.

DOLMAR
A member of the *Makita* Group

Seite / Page	Pos.	MS-4300.4 U	Teil-Nr. Part No. No. de pièce No. de pieza	Hinweise Notes Renseign. Nota	Bezeichnung	Spezifikation Specification	Description	Désignation	Denominación
2	74	1	367 126 114		BEDIENUNGSHANDGRIF FF KPL.		CONTROL LEVER ASS'Y	LEVIER DE RÉGLAGE, CPL.	BOTÓN DE MANDO, CPL.
2	75	1	367 188 657		GRIFFSCHALEN, SATZ		LEVER CASE, SET	POIGNÉE, JEU	MANGO, JUEGO
2	76	1	367 233 540		TORSIONSFEDER	11	TORSION SPRING	RESSORT À TORSION	MUELLE DE TORSIÓN
2	77	1	367 451 084		GASHEBEL		THROTTLE LEVER	ACCÉLÉRATEUR	PALANCA DEL ACELERADOR
2	78	1	367 233 541		TORSIONSFEDER	7	TORSION SPRING	RESSORT À TORSION	MUELLE DE TORSIÓN
2	79	1	367 451 083		GASHEBELSPERRE		STOP LEVER	TOUCHE DE BLOCAGE	TECLA DE BLOQUEO
2	80	1	367 453 524		FALTENSCHLAUCH		CORRUGATED TUBE	TUBE À SOUFFLETS	TUBO ONDULADO
2	81	1	367 168 711		BOWDENZUG		CONTROL CABLE	CÂBLE BOWDEN	TRACCIÓN BOWDEN
2	82	1	367 451 081		KABELKLEMME		CABLE HOLDER	CRAMP	COLLIER DE SERRAGE
2	83	1	367 451 500		SCHALTHEBEL		SWITCH LEVER	LEVIER DU COUPE CIRCUIT	MANO INTERRUPTOR
2	84	1	367 232 251		BLATTFEDER		LEAF SPRING	LAME RESSORT	RESORTE DE LA LÁMINA
2	85	1	367 451 253		SCHALTERDECKEL		SWITCH COVER	COUVERCLE COMMUTATEUR	CUBIERTA CONMUTADOR
2	86	1	367 638 972		KABEL		LEAD UNIT	CÂBLE	CABLE
2	87	1	367 188 657		GRIFFSCHALEN, SATZ		LEVER CASE, SET	POIGNÉE, JEU	MANGO, JUEGO
2	88	3	660 266 326		SCHNEIDSCHRAUBE	4X18	SCREW	VIS	TORNILLO
2	89	1	367 638 973		KABEL		LEAD UNIT	CÂBLE	CABLE

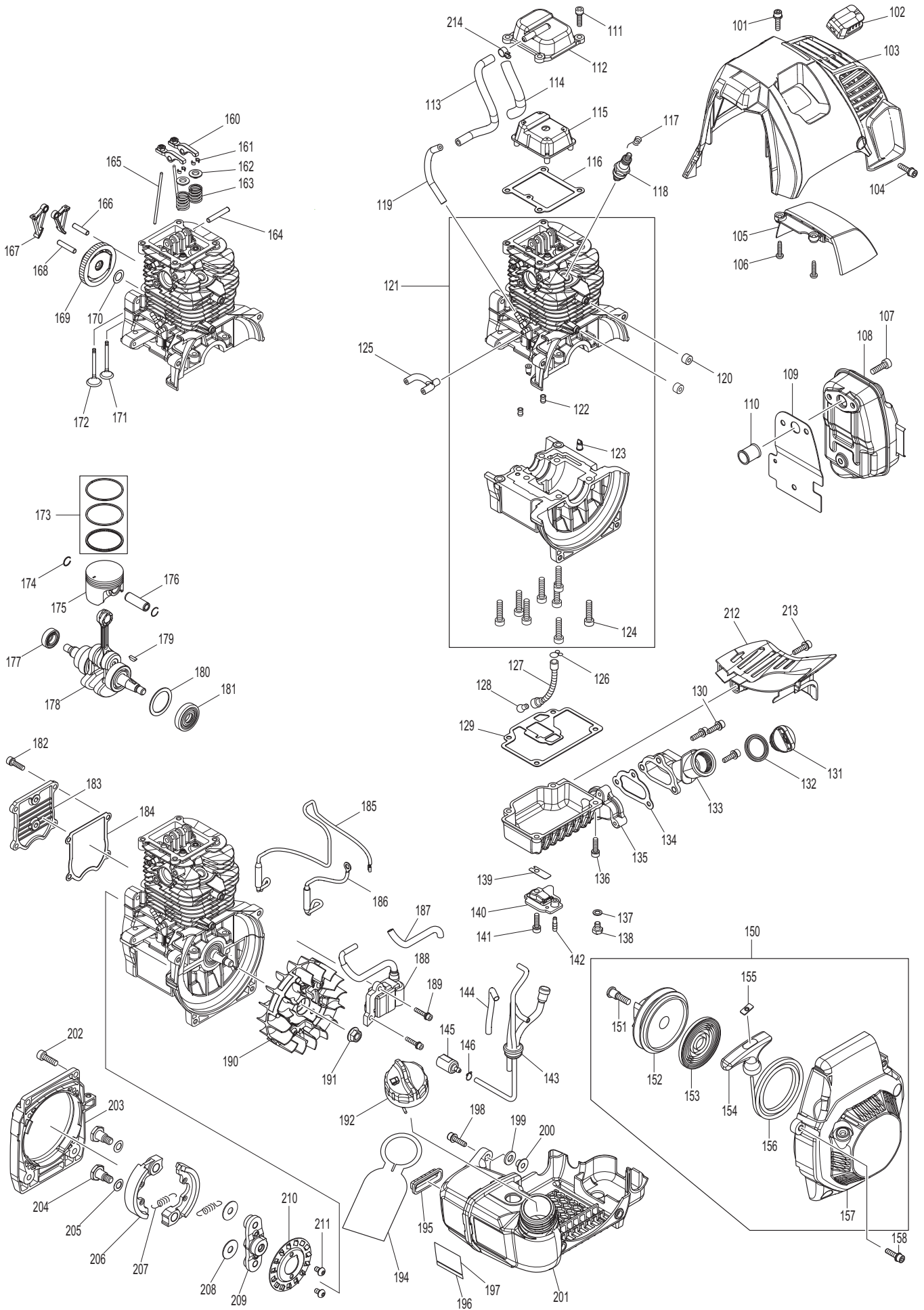

Seite / Page	Pos.	MS-4300.4 U	Teil-Nr. Part No. No. de pièce No. de pieza	Hinweise Notes Renseign. Nota	Bezeichnung	Spezifikation Specification	Description	Désignation	Denominación
3	101	1	320 922 233		SCHRAUBE	M5X20	HEX SOCKET HEAD BOLT	VIS	TORNILLO
3	102	1	374 424 302		STECKERKAPPE		PLUG CAP	CAPUCHON DE FICHE	TAPA DEL ENCHUFE
3	103	1	367 453 544		ZYLINDERHAUBE		CYLINDER COVER	CAPOT DE CYLINDRE	TAPA PARA CILINDRO
3	104	1	320 922 233		SCHRAUBE	M5X20	HEX SOCKET HEAD BOLT	VIS	TORNILLO
3	105	1	367 453 536		VERBRENNUNGSSCHUTZ		MUFFLER COVER	PROTECTION DE COMBUSTION	PROTECCIÓN CONTRA COMBUSTIÓN
3	106	2	660 265 995		GEWINDESCHNEIDSCHRAUBE	4X18	TAPPING SCREW	VIS TARAUEUSE	TORNILLO DE ROSCA CORTANTE
3	107	3	367 922 332		6KT-SCHRAUBE	M6X20	HEX. SOCKET HEAD BOLT	VIS HEXAGONAL	TORNILLO HEXAGONAL
3	108	1	367 168 715		SCHALLDÄMPFER		EXHAUST MUFFLER	POT D'ÉCHAPPEMENT	SILENCIADOR
3	109	1	367 346 574		DICHTUNG SCHALLDÄMPFER		MUFFLER GASKET	JOINT DE POT D'ÉCHAPPEMENT	JUNTA DEL SILENCIADOR
3	110	1	367 331 987		DISTANZBUCHSE		EXHAUST PORT SPACER	DOUILLE	CASQUILLO
3	111	4	367 922 226		SCHRAUBE	M5X18	HEX. SOCKET HEAD BOLT	VIS HEXAGONAL	TORNILLO HEXAGONAL
3	112	1	367 318 850		ABDECKUNG FÜR KIPPHEBEL, AUSSEN		ROCKER COVER OUTER	CAPOT POUR CULBUTEUR, EXT.	TAPA DE BALANCINES, EXT.
3	113	1	367 422 091		SCHLAUCH	5-160	TUBE	TUYAU	TUBO
3	114	1	367 454 424		FALTENSCHLAUCH		CORRUGATED TUBE	TUBE À SOUFFLETS	TUBO ONDULADO
3	115	1	367 453 529		ABDECKUNG FÜR KIPPHEBEL, INNEN		ROCKER COVER INNER	CAPOT POUR CULBUTEUR, INT.	TAPA DE BALANCINES, INT.
3	116	1	367 162 335		DICHTUNG, ABDECKUNG F. KIPPHEBEL		ROCKER COVER GASKET	JOINT, CAPOT POUR CULBUTEUR	JUNTA, TAPA DE BALANCINES CPL
3	117	1	367 324 891		STECKERKAPPENFEDER		PLUG CAP SPRING	RESSORT CAPUCHON DE FICHE	MUELLE TAPA DEL ENCHUFE
3	118	1	965 603 030		ZÜNDKERZE	NGK CMR6A	SPARK PLUG	BOUGIE	BUJÍA
3	118	1	367 196 721		MOTORWARTUNG SATZ	SET (MS-430.4 U, MS-4300.4 U) INC. 118,145,218,220,A 03	ENGINE MAINTENANCE KIT	JEU DE MAINTENANCE DE MOTEUR	JUEGO DE MANTENIMIENTO DE MOTOR
3	119	1	367 422 090		SCHLAUCH	3-85	TUBE	TUYAU	TUBO
3	120	2	367 452 049		DISTANZRING		SPACER	BAGUE D'ECARTEMENT	ANILLO DISTANCIADOR
3	121	1	367 135 557		ZYLINDERBLOCK-SATZ		CYLINDER BLOCK ASSEMBLY	BLOC DE CYLINDRES	BLOQUE DE CILINDROS
3	122	2	367 424 200		DISTANZBUCHSE		SPACER	DOUILLE	CASQUILLO
3	123	2	367 424 201		RÜCKSCHLAGVENTIL		CHECK VALVE	SOUPAPE DE RETENU	VÁLVULA ANTIRRETORNO
3	124	8	381 922 342		6KT-SCHRAUBE	M6X25	HEX. SOCKET HEAD BOLT	VIS HEXAGONAL	TORNILLO HEXAGONAL
3	125	1	381 422 099		SCHLAUCH		PIPE	TUYAU	TUBO
3	126	1	367 282 020		SCHLAUCHKLEMME		HOSE CLAMP	COLLIER	ABRAZADERA
3	127	1	367 424 301		ÖLLEITUNG		OIL TUBE	TUYAU DE L'HUILE	TUBERÍA DE ACEITE
3	128	1	367 325 666		GEWICHT F. ÖLLEITUNG		OIL WEIGHT	POIDS POUR TUYAU D'HUILE	PESA PARA EL TUBO DEL ACEITE
3	129	1	367 162 337		DICHTUNG		OIL CASE GASKET	JOINT	JUNTA
3	130	3	374 905 945		SCHRAUBE	M5X18	SOCKET HEAD BOLT	VIS	TORNILLO
3	131	1	388 650 150		ÖLDECKEL		OIL CAP	BOUCHON	TAPA
3	132	1	388 322 999		DICHTUNG		GASKET	JOINT	JUNTA

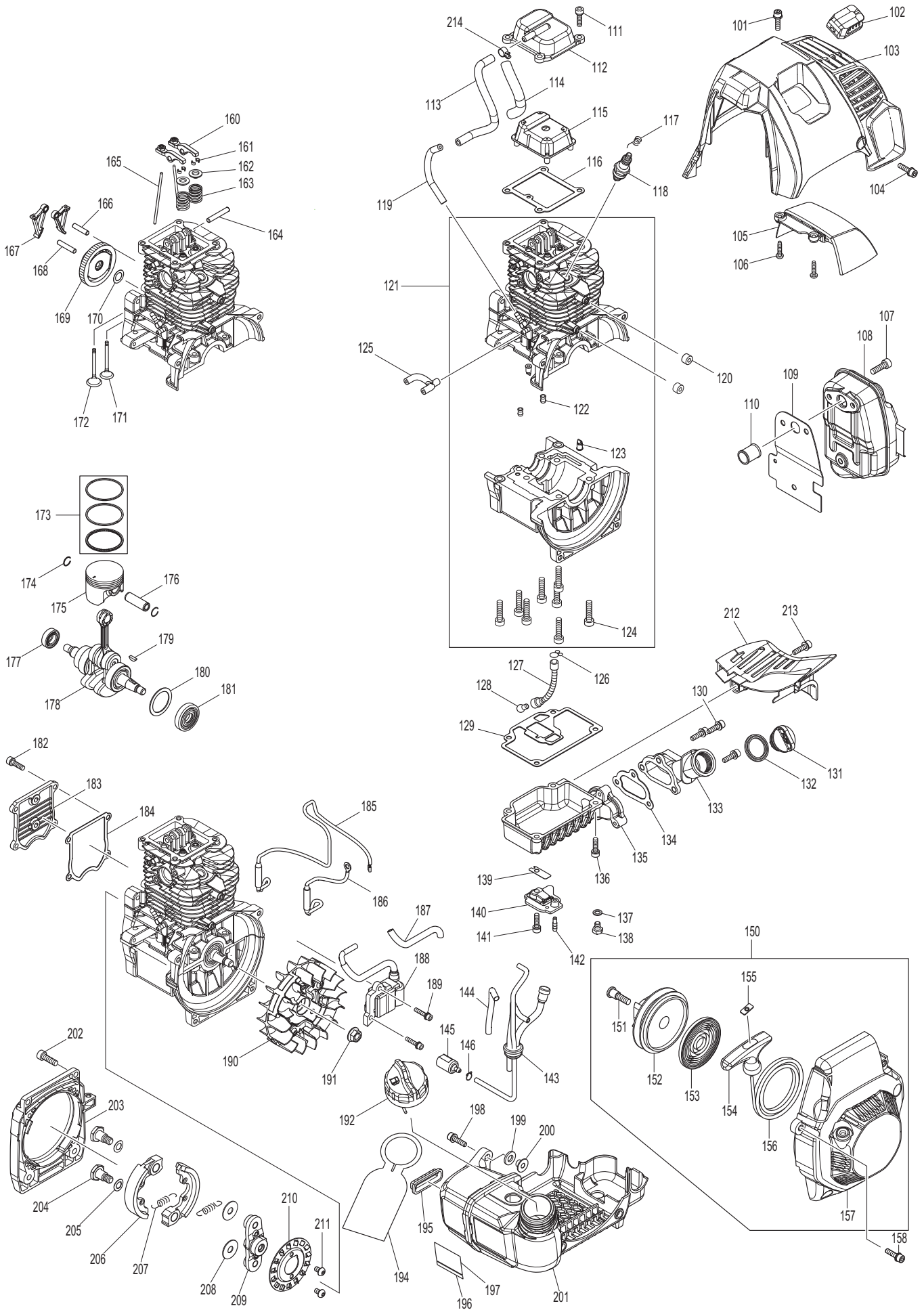

MS-4300.4 U

3

Motor kpl.
Motor cpl.
Moteur cpl.
Motor cpl.



 A member of the *Makita* Group

Seite / Page	Pos.	MS-4300.4 U	Teil-Nr. Part No. No. de pièce No. de pieza	Hinweise Notes Renseign. Nota	Bezeichnung	Spezifikation Specification	Description	Désignation	Denominación
3	133	1	367 453 538		ÖLLEITUNG		OIL PIPE	TUYAU DE L'HUILE	TUBERÍA DE ACEITE
3	134	1	367 162 338		DICHTUNG		OIL PIPE GASKET	JOINT	JUNTA
3	135	1	367 318 854		ÖLWANNE		OIL CASE	CUVETTE A HUILE	CÁRTER DE ACEITE
3	136	4	367 922 226		SCHRAUBE	M5X18	HEX. SOCKET HEAD BOLT	VIS HEXAGONAL	TORNILLO HEXAGONAL
3	137	1	367 346 305		DICHTUNG		GASKET	JOINT	JUNTA
3	138	1	367 266 611		6KT-SCHRAUBE	M6X8	HEXAGON BOLT	VIS À SIX PANS	TORNILLO HEXAGONAL
3	139	1	320 346 398		EINLASSMEMBRAN (REEDVALVE)		LEAD VALVE	MEMBRANE D'ADMISSION	VÁLVULA CON MEMBRANA DE ADMISIÓN
3	140	1	367 318 851		STOPPER FÜR REEDVALVE		RETAINER PLATE	FILTRE EN FEUTRE	FILTRO DE FIELTRO
3	141	1	367 922 226		SCHRAUBE	M5X18	HEX. SOCKET HEAD BOLT	VIS HEXAGONAL	TORNILLO HEXAGONAL
3	142	1	367 325 665		ANSCHLUßSTÜCK		JOINT PIPE	RACCORD	RACOR
3	143	1	367 168 724		SCHLAUCH KPL.		TUBE COMPLETE	TUBE CPL.	TUBO CPL.
3	144	1	367 454 426		SPIRALSCHLAUCH	6-80	SPIRAL TUBE	TUBE	TUBO
3	145	1	367 163 518		BENZINFILTER		GASOLIN FILTER	FILTRE D'ESSENCE	FILTRO DE GASOLINA
3	145	1	367 196 721		MOTORWARTUNG SATZ	SET (MS-430.4 U, MS-4300.4 U) INC. 118,145,218,220,A 03	ENGINE MAINTENANCE KIT	JEU DE MAINTENANCE DE MOTEUR	JUEGO DE MANTENIMIENTO DE MOTOR
3	146	1	367 282 020		SCHLAUCHKLEMME		HOSE CLAMP	COLLIER	ABRAZADERA
3	150	1	367 126 119		STARTER KPL.		STARTER COVER ASS'Y	DÉMARREUR COMPLET	ARRANCADOR CPL.
3	151	1	320 266 634		SCHRAUBE	M6X20	SET SCREW	VIS	TORNILLO
3	152	1	367 452 288		SEILTROMMEL		REEL	TAMBOUR DE CÂBLE	TAMBOUR PARA CORDÓN
3	153	1	377 504 003		RÜCKHOLFEDER		SPIRAL SPRING	RESSORT RAPPEL	RESORTE RETENCION
3	154	1	383 500 102		ANWERFGRIF		STARTER KNOB	POIGNEE DE LANCEMENT	TIRADOR DE ARRANQUE
3	155	1	388 500 103		SCHEIBE		STOPPER	DISQUE	ARANDELA
3	156	1	367 444 027		ANWERFSEIL		STARTER ROPE	CORDE DE LANCEUR	CUERDA DE ARRANQUE
3	157	1	367 453 534		ANWERFGEHÄUSE		STARTER COVER	BOÎTIER DISPOS. DE DÉMARRAGE	CAJA DISPOS. DE ARRANQUE
3	158	4	320 922 233		SCHRAUBE	M5X20	HEX SOCKET HEAD BOLT	VIS	TORNILLO
3	160	2	367 126 116		KIPPEBEL KPL.		ROCKER ARM ASS'Y	CULBUTEUR CPL.	GRUPO DEL BALANCÍN CPL.
3	161	4	367 331 990		SPLINT		COTTER	GOUPILLE	PASADOR
3	162	2	367 331 991		FEDERTELLER		SPRING RETAINER	CUVETTE DE RESSORT	CAJA DE RESORTE
3	163	2	367 234 238		DRUCKFEDER	11	COMPRESSION SPRING	RESSORT DE PRESSION	RESORTE DE PRESIÓN
3	164	1	367 256 200		STIFT	5	PIN	GOUPILLE	PASADOR
3	165	2	367 256 866		STÖSSELSTANGE	2.5	ROD	TIGE-POUSOIR	BARRA DE EMPUJADOR
3	166	1	367 268 238		STIFT	5	PIN	GOUPILLE	PASADOR
3	167	2	367 313 236		NOCKENHEBEL		CAM LIFTER	LEVIER A CAMES	LEVAS
3	168	1	320 256 186		STIFT	5	PIN	GOUPILLE	PASADOR
3	169	1	367 126 115		NOCKENRAD KPL.		CAM GEAR ASS'Y	PIGNON DE DISTRIBUTION CPL.	GRUPO DEL ÁRBOL DE LEVAS CPL.
3	170	1	367 261 127		SCHEIBE	10 (TEFLON)	WASHER	RONDELLE	ARANDELA
3	171	1	367 326 158		AUSLASSVENTIL		EXHAUST VALVE	SOUPAPE D'EMISSION	VÁLVULA DE ESCAPE
3	172	1	367 326 157		EINLASSVENTIL		INTAKE VALVE	VALVE D'ADMISSION	VÁLVULA DE ADMISIÓN

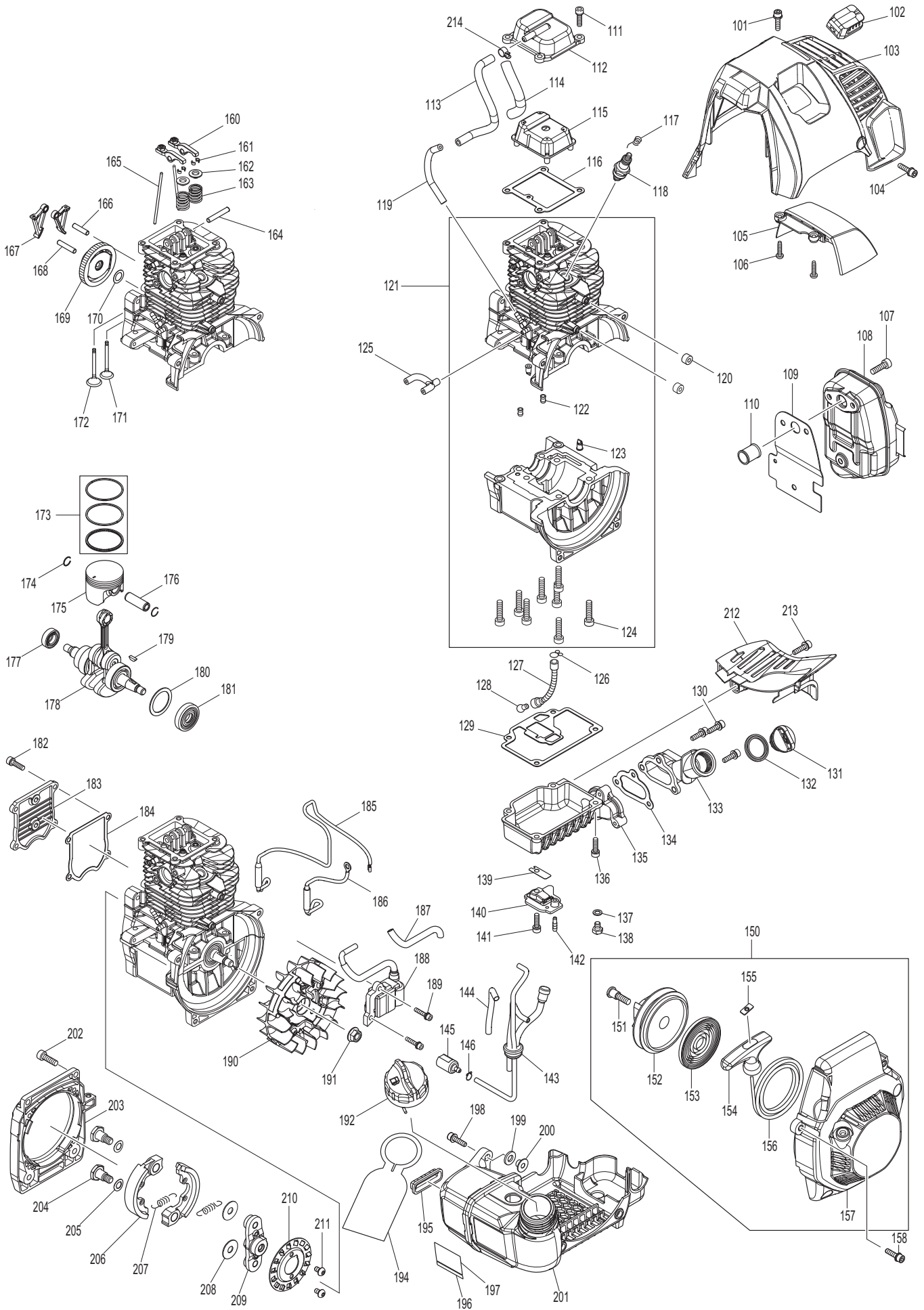

MS-4300.4 U

3

Motor kpl.
Motor cpl.
Moteur cpl.
Motor cpl.



 A member of the *Makita* Group

Seite / Page	Pos.	MS-4300.4 U	Teil-Nr. Part No. No. de pièce No. de pieza	Hinweise Notes Renseign. Nota	Bezeichnung	Spezifikation Specification	Description	Désignation	Denominación
3	173	1	367 196 667		KOLBENRING-SATZ		PISTON RING SET	JEU DE SEGMENTS DE PISTON	JUEGO DE SEGMENTOS DEL PISTÓN
3	174	2	367 233 983		SPRENGRING		CLIP	ANNEAU RESSORT	ANILLO ELÁSTICO
3	175	1	367 318 853		KOLBEN		PISTON	PISTON	PISTÓN
3	176	1	367 268 285		KOLBENBOLZEN		PISTON PIN	AXE DE PISTON	BULÓN DEL PISTÓN
3	177	1	367 213 685		ÖLDICHTUNG	12	OIL SEAL	JOINT ÉTANCHE À L'HUILE	RETÉN DE ACEITE
3	178	1	367 126 121		KURBELWELLE KPL.	INC. 177,180,181	CRANKSHAFT ASS'Y	VILEBREQUIN CPL.	CIGÜEÑAL CPL.
3	179	1	367 254 040		SCHEIBENFEDER	3	WOODRUFF KEY	CLAVETTE	CHAVETA
3	180	1	367 267 425		FLACHSCHEIBE	26	FLAT WASHER	RONDELLE PLATE	ARANDELA
3	181	1	367 213 537		ÖLDICHTUNG	12	OIL SEAL	JOINT ÉTANCHE À L'HUILE	RETÉN DE ACEITE
3	182	4	367 266 086		6KT-SCHRAUBE	M5X16	HEX. SOCKET HEAD BOLT	VIS HEXAGONAL	TORNILLO HEXAGONAL
3	183	1	367 318 856		ABDECKUNG F.NOCKENRAD		CAMGEAR COVER	CAPOT	TAPA D. PIÑÓN D. ÁRB. DE LEV.
3	184	1	367 162 334		DICHTUNG		CAM GEAR COVER GASKET	JOINT	JUNTA
3	185	1	367 638 974		KABEL		LEAD UNIT	CÂBLE	CABLE
3	186	1	367 638 975		KABEL		LEAD UNIT	CÂBLE	CABLE
3	187	1	367 444 021		SCHLAUCH		TUBE	GAINE	TUBO
3	188	1	367 168 714		ZÜNDSPULE		IGNITION COIL	BOBINE D' ALLUMAGE	BOBINA DE ENCENDIDO
3	189	2	367 266 602		6KT-SCHRAUBE	M4X20	HEX. SOCKET HEAD BOLT	VIS HEXAGONAL	TORNILLO HEXAGONAL
3	190	1	367 126 122		POLRAD KPL.		FLYWHEEL COMPLETE	ROUE POLAIRE CPL.	VOLANTE ENCEND. CPL.
3	191	1	367 264 075		6KT-MUTTER MIT BUND	M8	HEXAGONAL NUT WITH COLLAR	ECROU HEXAGONAL	TUERCA HEXAGONAL
3	192	1	367 125 728		KRAFTSTOFFTANK DECKEL KPL.		FUEL TANK CAP ASSEMBLY	BOUCHON RESERVOIR CPL., CARBURANT	TORNILLO DE CIERRE CPL., COMBUSTIBLE
3	194	1	367 810 455		HINWEISSCHILD F. KRAFTSTOFFART		CAUTION PLATE	PLAQUE POUR TYPE DE CARBURANT	ETIQUETA DE INDICACIÓN
3	195	1	374 424 081		GUMMIDÄMPFER		VIBRATION DAMPER	AMORTISSEUR DE VIBRATIONS	AMORTIGUADOR DE VIBRACIONES
3	196	1	367 897 220		SCHILD	SERIAL NO.	LABEL	PLAQUE	CALCOMANIA
3	197	1			ABGASAUFKLEBER	EU	GAS EMISSION APPROVAL LABEL	PLAQUE, GAZ D'ÉCHAPPEMENT	CALCOMANIA, GAS DE ESCAPE
3	198	1	320 922 233		SCHRAUBE	M5X20	HEX SOCKET HEAD BOLT	VIS	TORNILLO
3	199	1	367 261 152		GUMMISCHEIBE	8	RUBBER WASHER	RONDELLE EN CAOUTCHOUC	ARANDELA DE GOMA
3	200	1	367 331 988		DISTANZBUCHSE		SPACER	DOUILLE	CASQUILLO
3	201	1	367 168 718		KRAFTSTOFFTANK		FUEL TANK	RESERVOIR D'ESSENCE	DEPÓSITO DE COMBUSTIBLE
3	202	4	367 922 332		6KT-SCHRAUBE	M6X20	HEX. SOCKET HEAD BOLT	VIS HEXAGONAL	TORNILLO HEXAGONAL
3	203	1	367 318 852		MOTORSOCKEL		ENGINE BASE	SOCLE	BASE
3	204	2	367 266 597		6KT-BUNDSCHRAUBE	M8	SHOULDER HEX. BOLT	VIS HEXAGONAL	TORNILLO HEXAGONAL
3	205	2	367 267 832		WELLENSCHEIBE	10	WAVE WASHER	RONDELLE	ARANDELA AJUSTADA AL EJE
3	206	2	367 313 238		FLIEHGEWICHT		CLUTCH SHOE	MASSELOTTE	PESO CENTRIFUGA
3	207	2	367 231 880		ZUGFEDER	5	TENSION SPRING	RESSORT DE TRACTION	MUELLE DE TRACCIÓN
3	208	2	367 267 428		FLACHSCHEIBE	8	FLAT WASHER	RONDELLE PLATE	ARANDELA
3	209	1	367 313 239		KUPPLUNGSNABE		CLUTCH HUB	MOYEU D' EMBRAYAGE	CUBO DE EMBRAGUE
3	210	1	367 346 576		LÜFTERTELLER		FAN PLATE	PLAQUE	PLACA

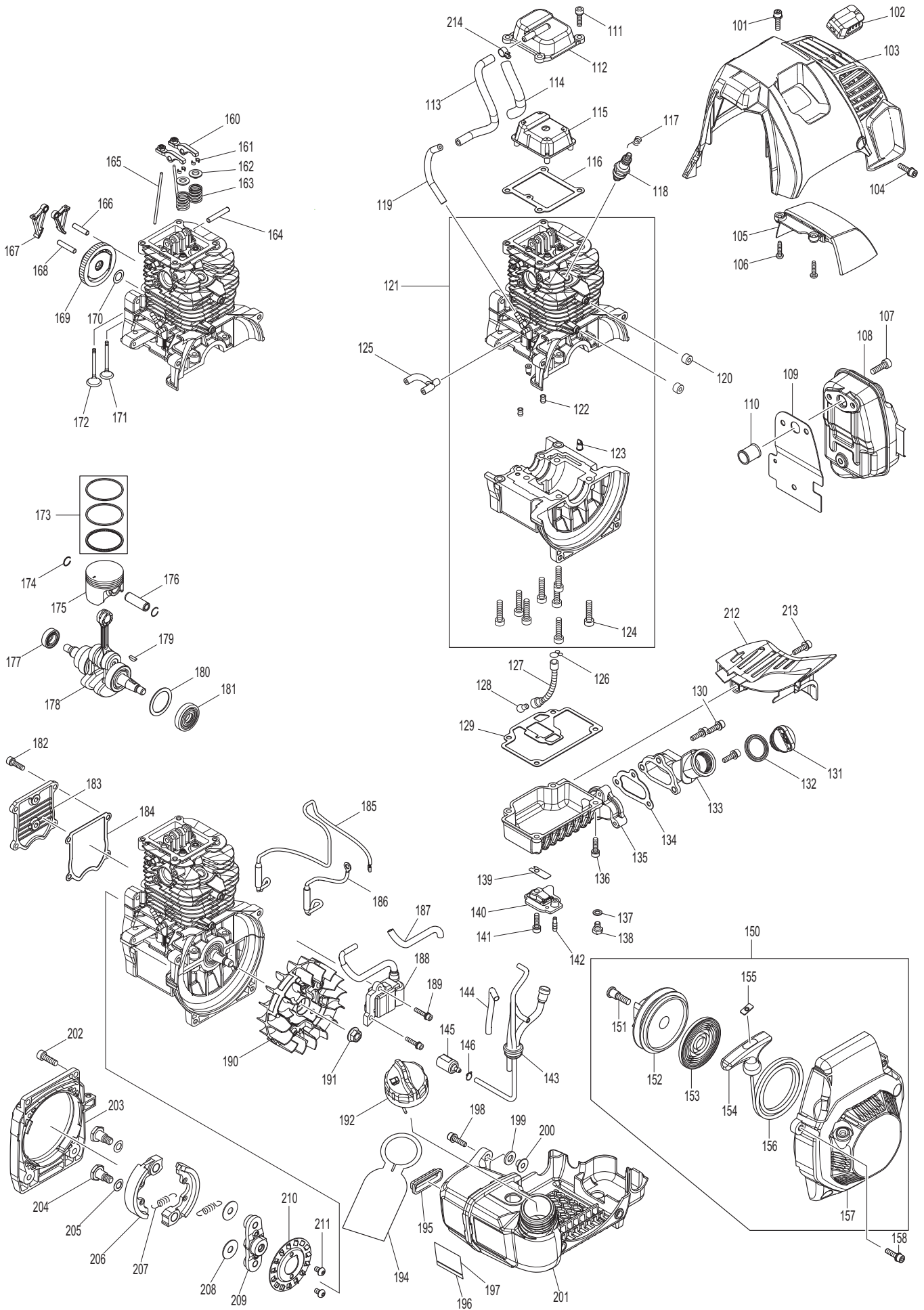

MS-4300.4 U

3

Motor kpl.
Motor cpl.
Moteur cpl.
Motor cpl.
DOLMAR

 A member of the *Makita* Group

Seite / Page	Pos.	MS-4300.4 U	Teil-Nr. Part No. No. de pièce No. de pieza	Hinweise Notes Renseign. Nota	Bezeichnung	Spezifikation Specification	Description	Désignation	Denominación
3	211	2	367 266 461		HALBRUNDSCHRAU BE	M5X8	H.S.BUTTON HEAD SCREW	VIS	TORNILLO
3	212	1	367 453 530		VERBRENNUNGSS CHUTZ		MUFFLER PLATE	PROTECTION DE COMBUSTION	PROTECCIÓN CONTRA COMBUSTIÓN
3	213	1	320 922 233		SCHRAUBE	M5X20	HEX SOCKET HEAD BOLT	VIS	TORNILLO
3	214	1	367 345 918		SCHLAUCHKLEMME		HOSE CLAMP	COLLIER	ABRAZADERA
3	240	1	367 819 430	ohne Abb., w/o picture	SICHERHEITSANHÄ NGER	DE, FR	CAUTION TAG	PLAQUE	CALCOMANIA
3	240	1	367 819 431	ohne Abb., w/o picture	SICHERHEITSANHÄ NGER	PL, AT, SE	CAUTION TAG	PLAQUE	CALCOMANIA
3	241	1	367 898 806	ohne Abb., w/o picture	SCHILD	MS-4300.4U	LABEL	PLAQUE	CALCOMANIA

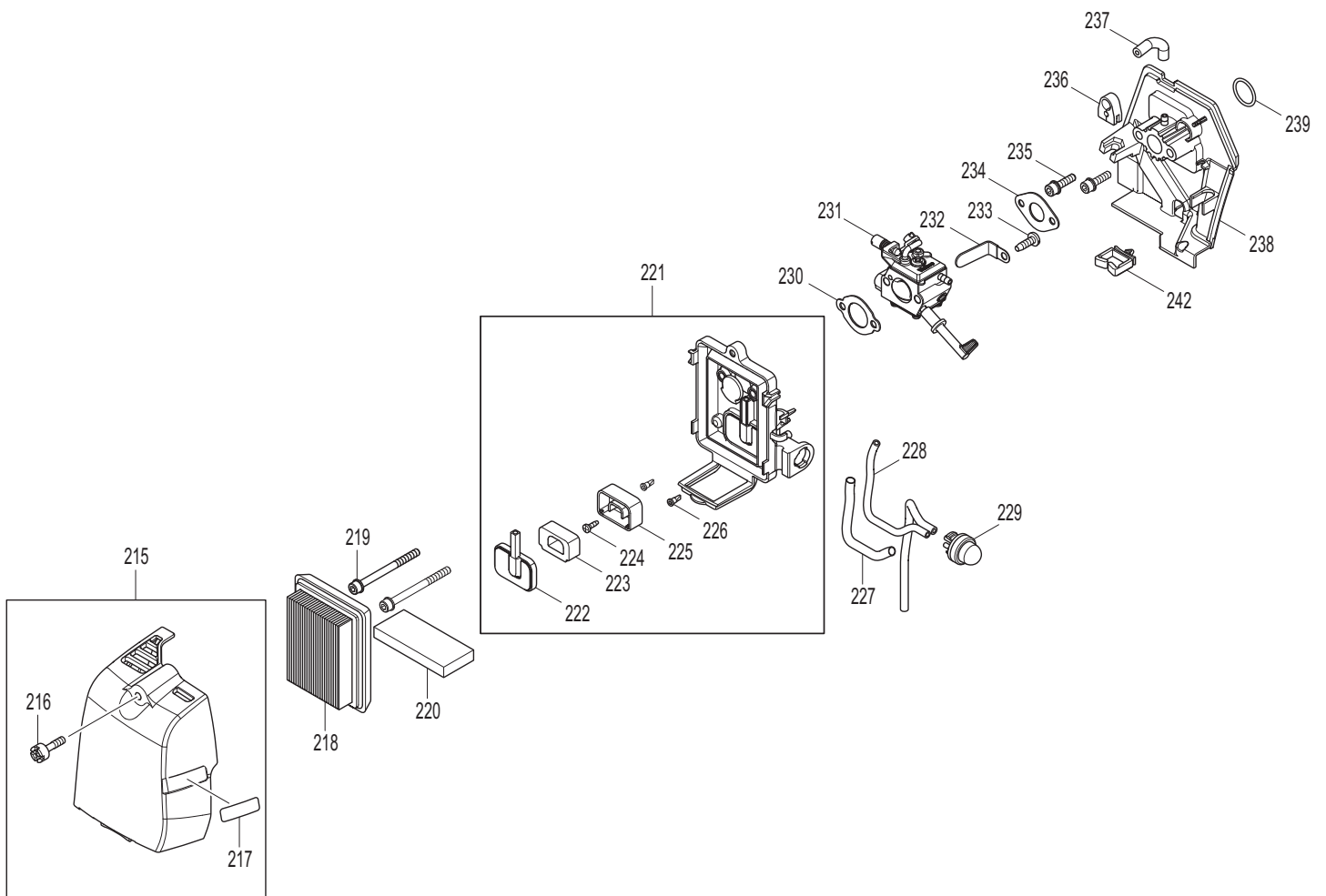

MS-4300.4 U

4

Vergaser, Luftfilter
Carburetor, air filter
Carburateur, filtre à air
Carburador, filtro de aire

DOLMAR
A member of the *Makita* Group

Seite / Page	Pos.	MS-4300.4 U	Teil-Nr. Part No. No. de pièce No. de pieza	Hinweise Notes Renseign. Nota	Bezeichnung	Spezifikation Specification	Description	Désignation	Denominación
4	215	1	367 126 118		LUFTFILTERDECKEL KPL.		CLEANER COVER ASSEMBLY	COUVERCLE DE FILTRE A AIR CPL.	CUBIERTA DEL FILTRO DE AIRE CPL.
4	215	1	367 801 044		HINWEISSCHILD		INDICATION LABEL	PLAQUE	ETIQUETA DE INDICACIÓN
4	216	1	367 266 743		6KT-SCHRAUBE	M5X20	HEX. SOCKET HEAD BOLT	VIS HEXAGONAL	TORNILLO HEXAGONAL
4	217	1	367 898 844		HINWEISSCHILD		INDICATION LABEL	PLAQUE	ETIQUETA DE INDICACIÓN
4	218	1	367 442 181		LUFTFILTER		ELEMENT AIR CLEANER	FILTRE À AIR	FILTRO DE AIRE
4	218	1	367 196 721		MOTORWARTUNG SATZ	SET (MS-430.4 U, MS-4300.4 U) INC. 118,145,218,220,A 03	ENGINE MAINTENANCE KIT	JEU DE MAINTENANCE DE MOTEUR	JUEGO DE MANTENIMIENTO DE MOTOR
4	219	2	367 266 601		6KT-SCHRAUBE	M5X60	HEX. SOCKET HEAD BOLT	VIS HEXAGONAL	TORNILLO HEXAGONAL
4	220	1	367 443 173		LUFTFILTER		ELEMENT AIR CLEANER	FILTRE À AIR	FILTRO DE AIRE
4	220	1	367 196 721		MOTORWARTUNG SATZ	SET (MS-430.4 U, MS-4300.4 U) INC. 118,145,218,220,A 03	ENGINE MAINTENANCE KIT	JEU DE MAINTENANCE DE MOTEUR	JUEGO DE MANTENIMIENTO DE MOTOR
4	221	1	367 126 117		LUFTFILTERBODEN KPL.		AIR CLEANER PLATE ASS'Y	PLAQUE DE FILTRE A AIR CPL.	GRUPO DE LA PLANCHA DEL FILTRO
4	222	1	381 162 346		ÖLSEPARATOR		SEPARATOR PLATE	SÉPARATEUR D'HUILE	SEPARADOR DEL ACEITE
4	223	1	381 352 020		NETZGEWEBE		SEPARATOR MESH	TISSU	ENTRESIJO
4	224	1	320 266 007		GEWINDESCHNEIDS CHRAUBE	3,0X10	TAPPING SCREW BIND	VIS TARAUDEUSE	TORNILLO DE ROSCA CORTANTE
4	225	1	381 453 865		SEPERATORGEHÄU SE		SEPARATOR CASE	CARTER	CÁRTER
4	226	2	367 424 316		RÜCKSCHLAGVENTI L		CHECK VALVE	SOUPAPE DE RETENU	VÁLVULA ANTIRRETORNO
4	227	1	367 454 425		SPIRALSCHLAUCH	6-100	SPIRAL TUBE	TUBE	TUBO
4	228	1	320 422 074		SCHLAUCH	3-120	TUBE	TUYAU	TUBO
4	229	1	010 155 010		KRAFTSTOFFPUMPE	PRIMER	PRIMER	POMPE À CARBURANT	BOMBA DE COMBUSTIBLE
4	230	1	367 442 196		DICHTUNG		CARBURATOR GASKET	JOINT	JUNTA
4	231	1	367 126 339		VERGASER KPL.		CARBURETOR ASSY.	CARBURATEUR CPL.	CARBURADOR CPL.
4	232	1	367 345 963		KLEMMSCHELLE		CLAMP	COLLIER DE SERRAGE	ABRAZADERA DE SUJECIÓN
4	233	1	660 266 388		SCHNEIDSCHRAUBE	5X16	SCREW	VIS	TORNILLO
4	234	1	367 442 197		DICHTUNG		CARBURATOR GASKET	JOINT	JUNTA
4	235	2	320 922 233		SCHRAUBE	M5X20	HEX SOCKET HEAD BOLT	VIS	TORNILLO
4	236	1	367 424 489		GUMMITÜLLE		GROMMET	GAIN CAOUTCHOUC	BOQUILLA DE GAUCHO
4	237	1	320 422 080		SCHLAUCH	3-35	TUBE	TUYAU	TUBO
4	238	1	367 142 128		ZWISCHENFLANSCH KPL.		INSULATOR COMPLETE	BRIDE INTERMÉDIAIRE	BRIDA INTERMEDIA
4	239	1	367 213 642		O-RING	18	O-RING	JOINT TORIQUE	ANILLO DE GUARNICIÓN
4	242	1	367 451 825		KLAMMER		CLAMP	CRAMPON	GRAPA

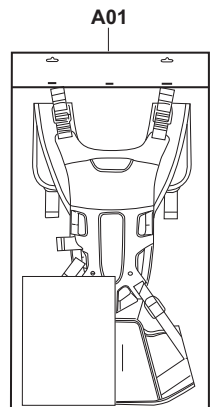
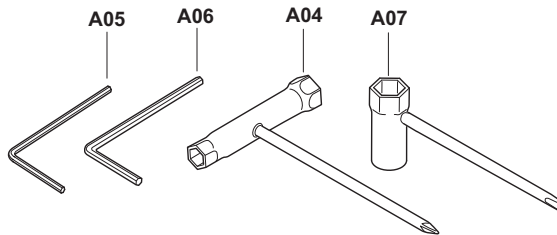
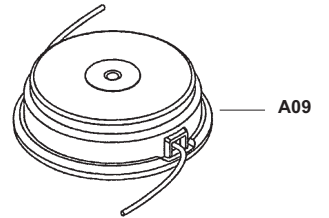
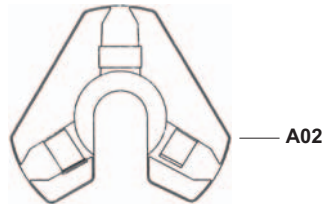
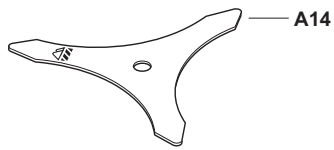
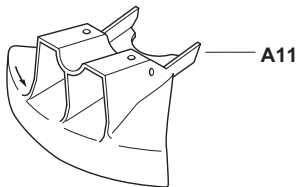
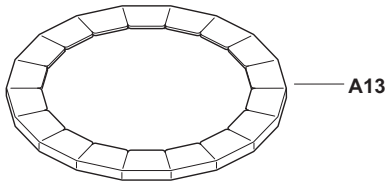
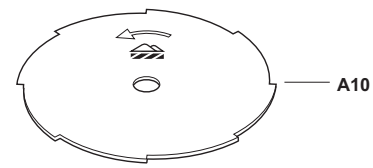

MS-4300.4 U

5

Werkzeuge, Zubehör
Tools, accessories
Outils, accessoires
Herramientas, accesorios

DOLMAR
A member of the *Makita* Group

Seite / Page	Pos.	MS-4300.4 U	Teil-Nr. Part No. No. de pièce No. de pieza	Hinweise Notes Renseign. Nota	Bezeichnung	Spezifikation Specification	Description	Désignation	Denominación
5	A01	1	381 196 335		SCHULTERGURT KPL.	DOLMAR	BAND ASSEMBLY SET	BRETELLE CPL., SET	HARNESS, SET
5	A02	1	367 451 252		TRANSPORTSCHU TZ		TOOL COVER	ENVELOPPE	TAPA PROTECTORA
5	A03	1	980 008 124		ÖLFLASCHE	100ml DOLMAR	OIL SET	BIDON, HUILE	BOTELLA, ACEITE
5	A03	1	367 242 072	PL	ÖLFLASCHE, LEER	w/o oil	OIL BOTTLE	BIDON	BOTELLA
5	A03	1	367 196 721		MOTORWARTUNG SATZ	SET (MS-430.4 U, MS-4300.4 U) INC. 118,145,218,220,A 03	ENGINE MAINTENANCE KIT	JEU DE MAINTENANCE DE MOTEUR	JUEGO DE MANTENIMIENTO DE MOTOR
5	A04	1	660 782 233		KOMBISCHLÜSSEL	10-16	BOX DRIVER	CLÉ COMBINÉE	LLAVE DE BUJIA
5	A05	1	940 804 000		6KT-STIFTSCHLÜS SEL	4	HEX. WRENCH	CLÉ MÂLE COUDÉE	LLAVE HEXAGONAL
5	A06	1	367 783 217		6KT-STIFTSCHLÜS SEL	5	HEX. WRENCH	CLÉ MÂLE COUDÉE	LLAVE HEXAGONAL
5	A07	1	367 782 238		KOMBISCHLÜSSEL	17	BOX WRENCH	CLÉ COMBINÉE	LLAVE DE BUJIA
5	A08	1	660 831 315	ohne Abb., w/o picture	ZUBEHÖRTASCHE	DOLMAR	ACCESSORY BAG	POCHETTE D'ACCESSOIRES	BOLSO DE ACCESORIOS
5	A09	1	367 228 821		FADENKOPF	Erstausrüstung	NYLON CUTTING HEAD	TETE A 2 FILS	CABEZA 2 CORT
5	A10	1	385 224 161	DE	MEISSELZAHN-SÄG EBLATT	ø 225x20	CHISEL TYPE SAW BLADE	SCIE CIRCULAIR	SIERRA CIRCULAR TIPO CHISEL
5	A10	1	385 224 171	SE	MEISSELZAHN-SÄG EBLATT	ø 200x20	CHISEL TYPE SAW BLADE	SCIE CIRCULAIR	SIERRA CIRCULAR TIPO CHISEL
5	A11	1	367 318 943	DE	SCHUTZHAUBE	225	PROTECTOR	CAPOT DE PROTECTION	CUBIERTA PROTECTORA
5	A11	1	367 318 942	SE	SCHUTZHAUBE	200	PROTECTOR	CAPOT DE PROTECTION	CUBIERTA PROTECTORA
5	A12	1	367 332 051		AUFNAHMESCHEIB E	ø 20	RECEIVE WASHER	DISQUE DE SUPPORT	DISCO DE SUJECIÓN
5	A13	2	367 450 573		TRANSPORTSCHU TZ		TOOL COVER	ENVELOPPE	TAPA PROTECTORA
5	A14	1	385 224 150		3-ZAHN-DICKICHTM ESSER	ø 300x25,4	STEEL BUSH CUTTER	LAME DE TAILLIS	CUCHILLA DE 3 DIENTES

- 1** Hauptrohr, Griff, Schutzhaube, Getriebegehäuse
 Pipe, handle, protector, gear case
 Tube, poignée, capot de protection, carter d.engrenages
 Tubo, mango, cubierta protectora, caja de engranajes
- 2** Bedienungshandgriff kpl.
 Control lever ass'y
 Levier de réglage, cpl.
 Botón de mando, cpl.
- 3** Motor kpl.
 Motor cpl.
 Moteur cpl.
 Motor cpl.
- 4** Vergaser, Luftfilter
 Carburetor, air filter
 Carburateur, filtre à air
 Carburador, filtro de aire
- 5** Werkzeuge, Zubehör
 Tools, accessories
 Outils, accessoires
 Herramientas, accesorios

	Zeichenerklärung	Key to symbols
=> 1999999 2000000 => 2003.04 => TI 2003/07 Acc. = { m Corr.	Produktion bis Serien-Nr. Neues Teil ab Serien-Nr. Neues Teil ab Jahr / Monat Siehe Technische Information Jahr / Nr. Zubehör (nicht im Lieferumfang) Keine Serienausführung, jedoch verwendbar Beinhaltet Positions-Nr. Meterware Druckfehlerberichtigung	Production to serial number New part from serial number New part from Year / Month See Technical Information Year / No. Accessories (not included in the delivery inventory) No standard execution, may be used Contains item number Sold by the meter Error correction
	Änderungen vorbehalten	Specifications subject to change without notice
	Légende	Explicación de símbolos
=> 1999999 2000000 => 2003.04 => TI 2003/07 Acc. = { m Corr.	Production jusqu'à n° de série Nouvelle pièce à partir du n° de série Nouvelle pièce à partir de année / mois Voir information technique année / n° Accessoires (non compris dans la livraison) Aucune exécut. en série, cependant utilisable contient n° de numéro Au mètre Rectification d'erreurs	Producción hasta N° de serie Pieza nueva a partir de N° de serie Pieza nueva a partir de año / mes Véase inform. técnico año / N° Accesorios (no incluido en la extensión del suministro) No es de serie, pero sirve Contiene pos N° Por metro Fe de erratas
	Changements sans préavis	Mejoras constructivas sin previo aviso