

Spare Parts List
Ersatzteilliste
Liste de pièces détachées
Lista de piezas de repuesto

2012-09

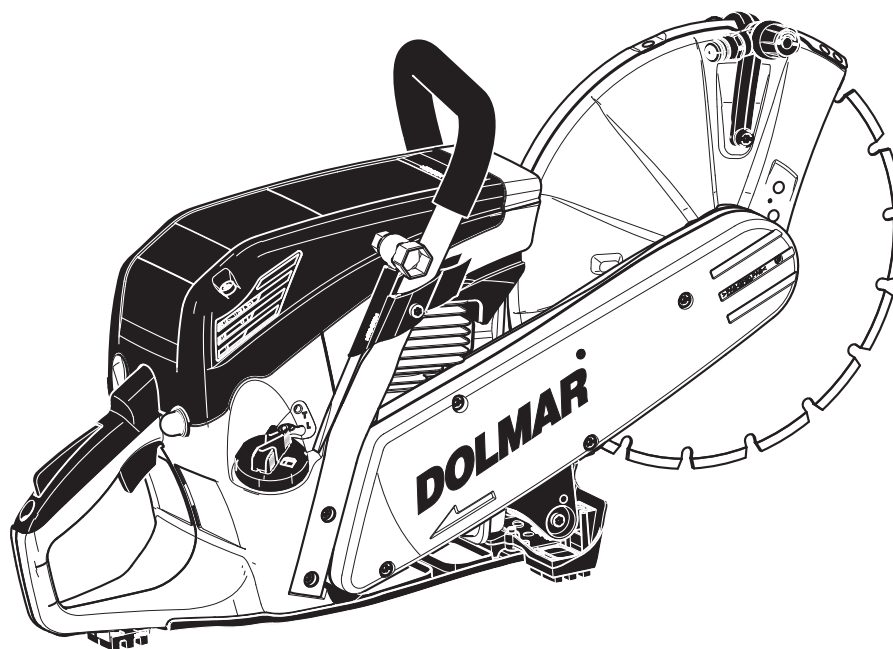

PC-6112
PC-6114

DOLMAR



A member of the *Makita* Group

995700087 (D, GB, F, E)

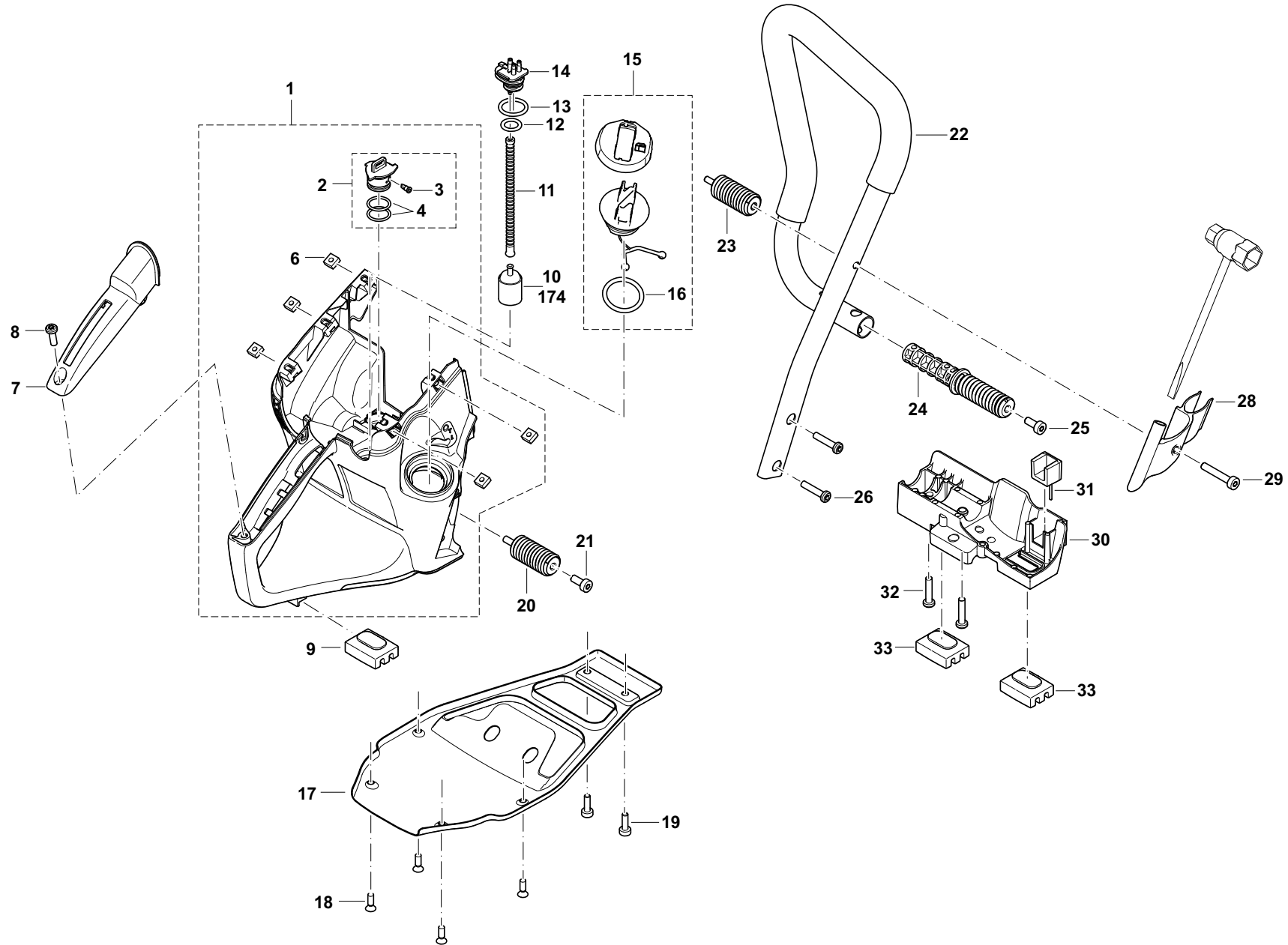

PC-6112, PC-6114

1

Tankeinheit und Handgriffe
Tank and handle grips
Réservoir et poignées
Depósito y mangos

DOLMAR
A member of the **Takita** Group

Seite / Page	Pos.	PC-6112	PC-6114	Teil-Nr. Part No. No. de pièce No. de pieza	Hinweise Notes Renseign. Nota	Bezeichnung	Spezifikation Specification	Description	Désignation	Denominación
1	1	1	1	315 114 101		KRAFTSTOFFTANK KPL. ROT		FUEL TANK CPL. RED	RÉSERVOIR CPL. ROUGE	DEPÓSITO CPL. ROJO
1	2	1	1	315 175 061		VENTILDECKEL KPL.		VALVE COVER CPL.	CAPOT SOUPAPE CPL.	TAPA VÁLVULA CPL.
1	3	1	1	010 175 021		LIPPENRUECKSCHLAGVENTIL		VALVE	SOUPAPE D' AERATION CPL.	VÁLVULA VENTILACION CPL.
1	4	2	2	963 217 020		O-RING	17X2 FKM	O-RING	BAGUE JOINT	ANILLO DE GUARNICIÓN
1	6	5	5	038 111 060		4KT-MUTTER	M5, SW10	SQUARE NUT	ECROU CARRÉ	TUERCA CUADR.
1	7	1	1	315 117 050		GRIFFOBERSCHALE		GRIP OUTER SHELL	COUILLE DE POIGNÉE SUPÉR.	CUBIERTA SUPER. EMPUÑADURA
1	8	1	1	913 455 164		INNENSTERN SCHRAUBE	5,5X16	SCREW	VIS	TORNILLO
1	9	1	1	315 114 060		GUMMIFUSS		RUBBER FOOT	PIED EN CAOUTCHOUC	PIE DE GOMA
1	10	1	1	963 601 122		SAUGKOPF KPL.		SUCTION HEAD	TÊTE D' ASPIRATION	CABEZA DE ASPIRACIÓN
1	11	1	1	315 114 140		KRAFTSTOFFLEITUNG		FUEL LINE	CONDUITE CARBURANT	CONDUCTO COMBUSTIBLE
1	12	1	1	963 213 030		O-RING	13X3	O-RING	BAGUE JOINT	ANILLO DE GUARNICIÓN
1	13	1	1	963 221 030		O-RING	21X3	O-RING	BAGUE JOINT	ANILLO DE GUARNICIÓN
1	14	1	1	315 114 150		KRAFTSTOFFNIPPEL		NIPPLE	RACCORD FILETÉ	RACOR
1	15	1	1	315 114 350		TANKDECKEL KPL.		TANK CAP ASSEMBLY	BOUCHON RESERVOIR CPL.	TORNILLO DE CIERRE CPL.
1	16	1	1	963 229 036		O-RING	29,3X3,6	PACKING RING	BAGUE-JOINT	ANILLO DE GUARNICION
1	17	1	1	315 114 110		BODENBLECH		BASE SHIELD	FOND EN TÔLE	CHAPA
1	18	4	4	913 850 155		INNENSTERN-SENKKOPF SCHRAUBE	5x15	SCREW	VIS	TORNILLO
1	19	2	2	908 005 125		INNENSTERN-SCHRAUBE	M5x12	SCREW	VIS	TORNILLO
1	20	2	2	315 114 220		DÄMPFUNGSFEDER KPL.		DAMPING SPRING, CPL.	RESSORT D'AMORTISS. CPL.	MUELLE DE AMORTIGUACIÓN CPL.
1	21	2	2	908 006 145		SCHRAUBE	M6x14	SCREW	VIS	TORNILLO
1	22	1	1	315 310 110		BÜGELGRIFF KPL.		TUBULAR HANDLE ASSY.	POIGNÉE TUBULAIRE CPL.	MANGO TUBULAR CPL.
1	23	1	1	315 114 200		DÄMPFUNGSFEDER KPL.		DAMPING SPRING, CPL.	RESSORT D'AMORTISS. CPL.	MUELLE DE AMORTIGUACIÓN CPL.
1	24	1	1	315 114 300		DÄMPFUNGSFEDER KPL.		DAMPING SPRING, CPL.	RESSORT D'AMORTISS. CPL.	MUELLE DE AMORTIGUACIÓN CPL.
1	25	1	1	908 006 145		SCHRAUBE	M6x14	SCREW	VIS	TORNILLO
1	26	2	2	913 455 204		SCHRAUBE	5,5x20	SCREW	VIS	TORNILLO
1	28	1	1	315 310 020		SHELLE BUEGELGRIFF		CLAMP HANDLE	BRIDE DE FIXATION	ABRAZADERA
1	29	1	1	908 006 355		INNENSTERN-SCHRAUBE	M6x35	SCREW	VIS	TORNILLO
1	30	1	1	315 114 121		STANDFUSS		STAND SUPPORT	PIED	PIE
1	31	1	1	315 114 090		DÄMPFER		DAMPER	AMORTISSEUR	AMORTIGUADOR
1	32	2	2	913 455 204		SCHRAUBE	5,5x20	SCREW	VIS	TORNILLO
1	33	2	2	315 114 060		GUMMIFUSS		RUBBER FOOT	PIED EN CAOUTCHOUC	PIE DE GOMA
1	174	1	1	963 601 240		FILZFILTER		FELT	FEUTRE	FIELTRO

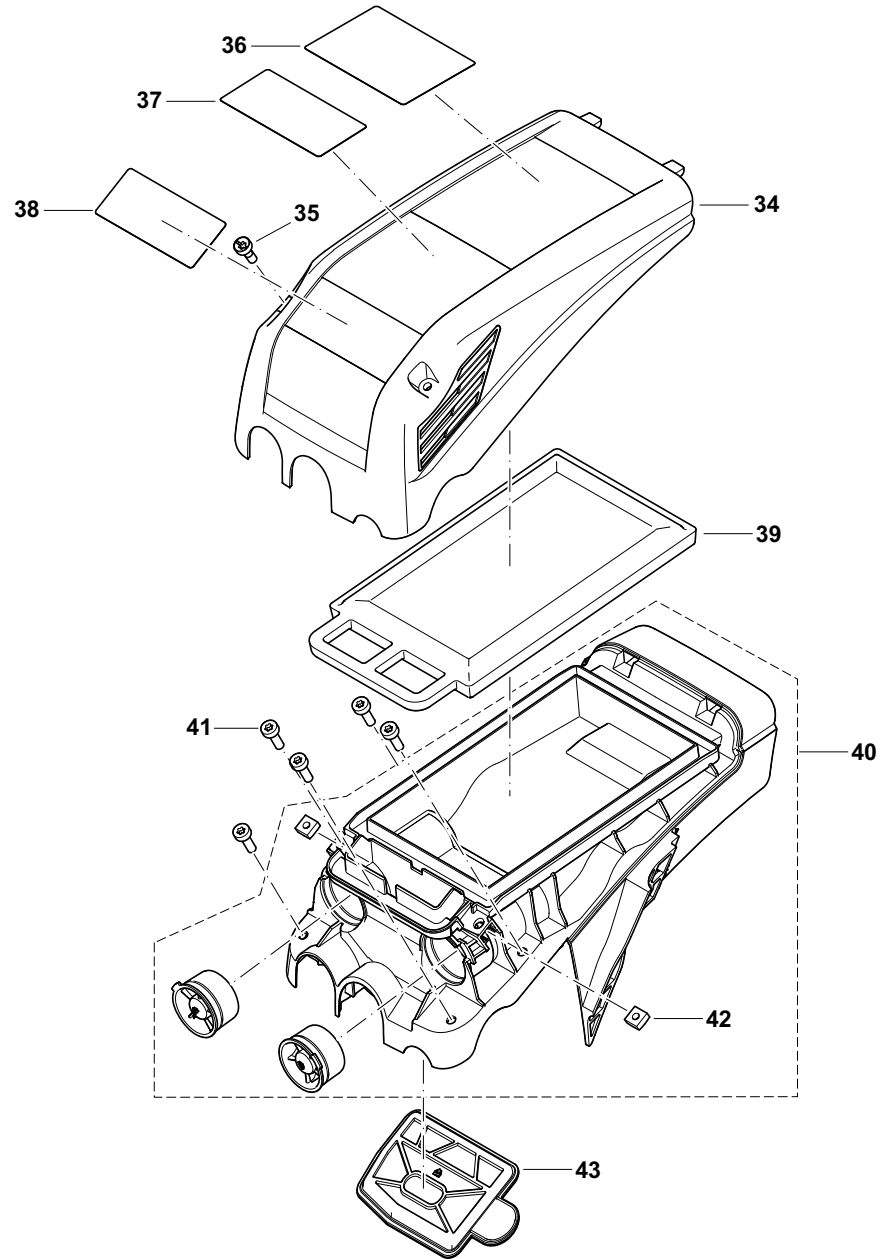

PC-6112, PC-6114

2

Abdeckhaube, Luftfilter
Hood, air filter
Capot protecteur, filtre à air
Cubierta protectora, filtro de aire

DOLMAR
A member of the **Takita** Group

Seite / Page	Pos.	PC-6112	PC-6114	Teil-Nr. Part No. No. de pièce No. de pieza	Hinweise Notes Renseign. Nota	Bezeichnung	Spezifikation Specification	Description	Désignation	Denominación
2	34	1	1	315 118 050		FILTERDECKEL KPL.		FILTER COVER ASSY.	CAPOT FILTRE CPL.	CUBIERTA PARA FILTRE CPL.
2	35	2	2	908 605 145		INNENSTERN-SCHLITZ-SCHRAUBE	M5x14	SCREW	VIS	TORNILLO
2	36	1	1	980 115 644		SCHILD SICHERHEITSHINWEISE	USA	LABEL, SAFETY INSTRUCTIONS	ETIQUETTE, INSTRUCTIONS DE SÉCURITÉ	ETIQUETA, SEGURIDAD
2	37	1	1	980 115 645		SCHILD WARNSYMBOL		LABEL, WARNING SYMBOLS	PLAQUE SYMBOLES D'AVERTISSEMENT	PLACA SÍMBOLOS DE ADVERTENCIA
2	38	1	1	980 114 999		SCHILD	2-TAKT MIX	LABEL	PLAQUE	CALCOMANIA
2	38	1	1	980 115 617		SCHILD	2-TAKT MIX (RUS)	LABEL	PLAQUE	CALCOMANIA
2	39	1	1	315 173 010		LUFTFILTER		AIR FILTER INSERT	FILTRE À AIR	FILTRO DE AIRE
2	40	1	1	315 118 040		ABDECKHAUBE KPL.	DOLMAR	HOOD CPL.	CAPOT PROTECTION CPL.	TAPA PROTECTORA CPL.
2	41	5	5	908 005 165		SCHRAUBE INNEN6RD ZK	M5x16	H.L. SOCKET HEAD BOLT	VIS	TORNILLO
2	42	2	2	038 111 060		4KT-MUTTER	M5, SW10	SQUARE NUT	ECROU CARRÉ	TUERCA CUADR.
2	43	1	1	315 173 020		INNENFILTER		INNER FILTER	FILTRE INTÉRIEUR	FILTRO DE AIRE INTERIOR

PC-6112, PC-6114

3

Schalldämpfer, Ansaugkrümmer
Muffler, connecting muff
Pot d' échappement, manchon de jonction
Silencioso, manguito de conexión

DOLMAR



A member of the **Trakita** Group

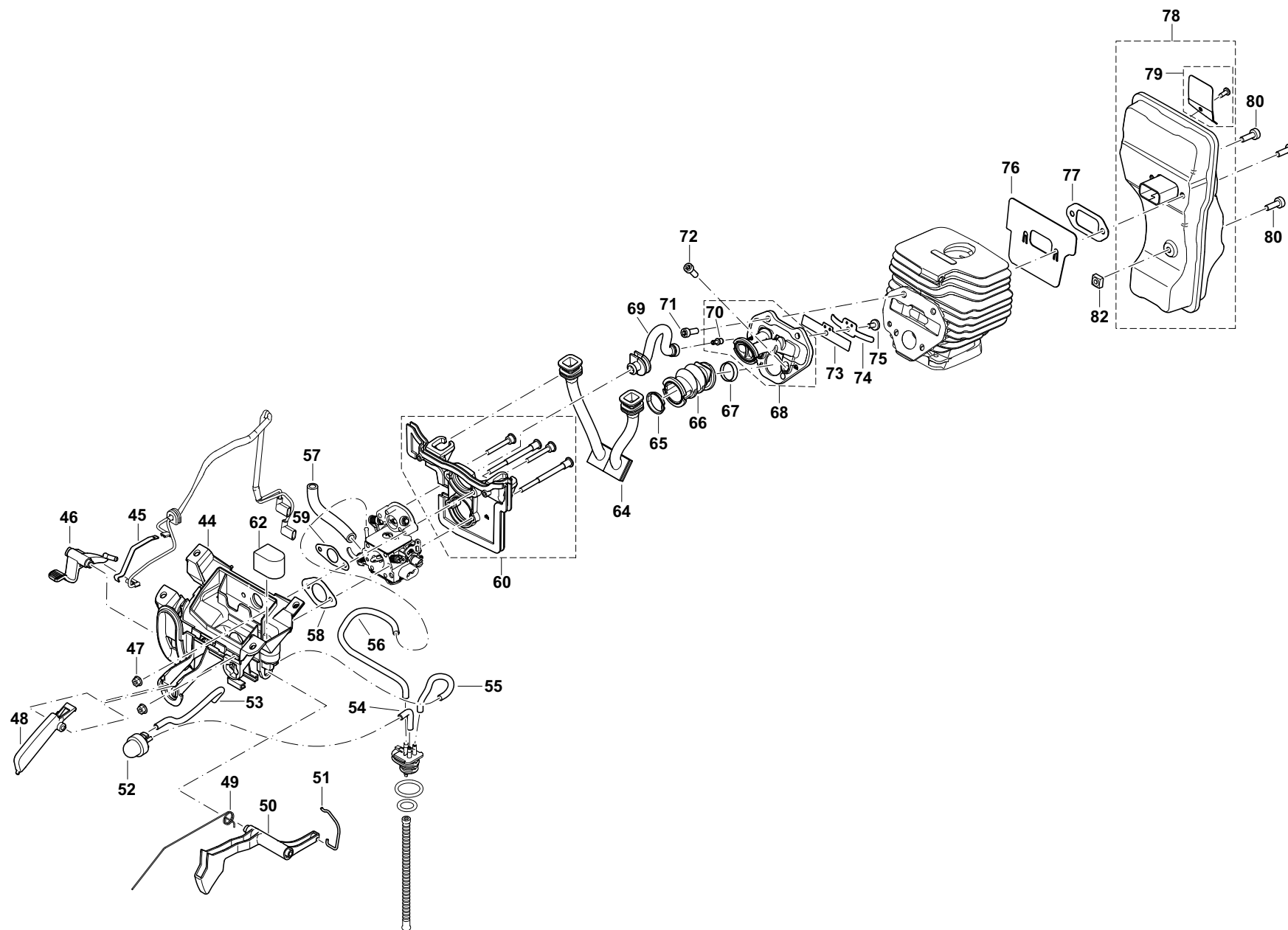

PC-6112, PC-6114

3

Schalldämpfer, Ansaugkrümmer
Muffler, connecting muff
Pot d' échappement, manchon de jonction
Silencioso, manguito de conexión

DOLMAR
A member of the **Takita** Group

Seite / Page	Pos.	PC-6112	PC-6114	Teil-Nr. Part No. No. de pièce No. de pieza	Hinweise Notes Renseign. Nota	Bezeichnung	Spezifikation Specification	Description	Désignation	Denominación
3	44	1	1	315 171 010		ANSAUGKRÜMMER		INTAKE MANIFOLD	MANCHON DE JONCTION	MANGUITO DE CONEXIÓN
3	45	1	1	315 146 010		KONTAKTFEDER		CONTACT SPRING	RESSORT DE CONTACT	RESORTE DE CONTACTO
3	46	1	1	315 146 020		CHOKEHEBEL		CHOKE LEVER	LEVIER DE STARTER	PALANCA ESTRANGULADOR DE AIRE
3	47	4	4	175 131 300		6KT-MUTTER MIT BUND		HEXAGONAL NUT WITH COLLAR	ECROU HEXAGONAL	TUERCA HEXAGONAL
3	48	1	1	315 117 010		GASHEBELSPERRE		CATCH LEVER	TOUCHE DE BLOPAGE	TECLA DE BLOQUEO
3	49	1	1	315 117 030		GASHEBELFEDER		SPRING	RESSORT	MUELLE
3	50	1	1	315 117 020		GASHEBEL		THROTTLE LEVER	ACCÉLÉRATEUR	PALANCA DEL ACELERADOR
3	51	1	1	315 117 040		GASGESTÄNGE		THROTTLE LINKAGE	TRINGLE D' ACCÉLÉRATION	VARILLA ACELERADOR
3	52	1	1	010 155 010		KRAFTSTOFFPUMPE	PRIMER	PRIMER	POMPE À CARBURANT	BOMBA DE COMBUSTIBLE
3	53	1	1	965 452 090		VITONSCHLAUCH	2,5/5,5mm x1m L=122mm	TUBE	GAINÉ	TUBO
3	54	1	1	965 452 090		VITONSCHLAUCH	2,5/5,5mm x1m L=40mm	TUBE	GAINÉ	TUBO
3	55	1	1	965 452 090		VITONSCHLAUCH	2,5/5,5mm x1m L=84mm	TUBE	GAINÉ	TUBO
3	56	1	1	965 452 660		VITONSCHLAUCH	5,6/3mmx1m EPA code, redL=200mm	TUBE	GAINÉ	TUBO
3	57	1	1	965 452 401		VITONSCHLAUCH	10X6 L=82mm	TUBE	GAINÉ	TUBO
3	58	1	1	315 155 020		DICHTUNG ANSAUGKRÜMMER		GASKET INTAKE MANIFOLD	JOINT	JUNTA
3	59	1	1	315 155 010		DICHTUNG LUFTKLAPPE		GASKET AIR VALVE	JOINT	JUNTA
3	60	1	1	315 114 080		ZWISCHENWAND KPL.		INTERMEDIATE WALL CPL.	GALANDAGE CPL.	PARED INTERMEDIA CPL.
3	62	1	1	315 173 050		SCHAUMSTOFFEINSATZ		FOAM-INSERT	MOUSSE DE NYLON	ESPUMA DE PLÁST.
3	64	2	2	315 173 040		ABSAUGSCHLAUCH		SUCTION PIPE	TUYAU FLEXIBLE	MANGUERA DE ASPIRACIÓN
3	65	1	1	024 131 032		EINSATZ FÜR ANSAUGSCHLAUCH		INSERT FOR SUCTION HOSE	PIÈCE P. TUYAU	SUPLEMENTO P. TUBO
3	66	1	1	315 131 030		ANSAUGSCHLAUCH		SUCTION HOSE	TUYAU D' ASPIRATION	TUBO DE ASPIRACIÓN
3	67	1	1	181 131 021		EINSATZ FÜR ANSAUGSCHLAUCH		INSERT	PIÈCE D' INSERTION	PIEZA DE CIERRE
3	68	1	1	315 131 100		LUFTSCHLAUCH KPL.		AIR HOSE CPL.	TUYAU CPL.	MANGA CPL.
3	69	1	1	315 131 120		IMPULSLEITUNG		IMPULSE LINE	LIGNE D'IMPULSION	IMPULSO DE LA LÍNEA
3	70	1	1	001 131 040		IMPULSNIPPEL		NIPPLE	RACCORD	NIPLE DE CONECTION
3	71	2	2	908 405 145		SCHRAUBE	M5x14	SCREW	VIS	TORNILLO
3	72	2	2	908 405 145		SCHRAUBE	M5x14	SCREW	VIS	TORNILLO
3	73	1	1	315 179 020		EINLASSMEMBRAN (REEDVALVE)		LEAD VALVE	MEMBRANE D'ADMISSION	VÁLVULA CON MEMBRANA DE ADMISIÓN
3	74	1	1	315 179 010		VENTILBLECH		VALVE STOPPER	TÔLE	CHAPA
3	75	1	1	908 004 085		SCHRAUBE	M4X8 INNEN6RD S LK	SCREW	VIS	TORNILLO
3	76	1	1	315 174 110		ABSCHIRMBLECH		COOLING PLATE	TÔLE DE PROTECTION	CHAPA DEFLECTORA
3	77	1	1	395 174 120		DICHTUNG		GASKET	JOINT	JUNTA
3	78	1	1	315 174 100		SCHALLDÄMPFER KPL.		MUFFLER CPL.	POT D'ECHAPPEMENT CPL.	SILENCIADOR CPL.
3	79	1	1	315 174 150		FUNKENSCHUTZSIEB KPL.		SPARK ARRESTER SCREEN CPL.	TAMIS CPL.	TAMIZ CPL.
3	80	3	3	908 005 165		SCHRAUBE INNEN6RD ZK	M5x16	H.L. SOCKET HEAD BOLT	VIS	TORNILLO
3	82	1	1	038 111 060		4KT-MUTTER	M5, SW10	SQUARE NUT	ECROU CARRÉ	TUERCA CUADR.

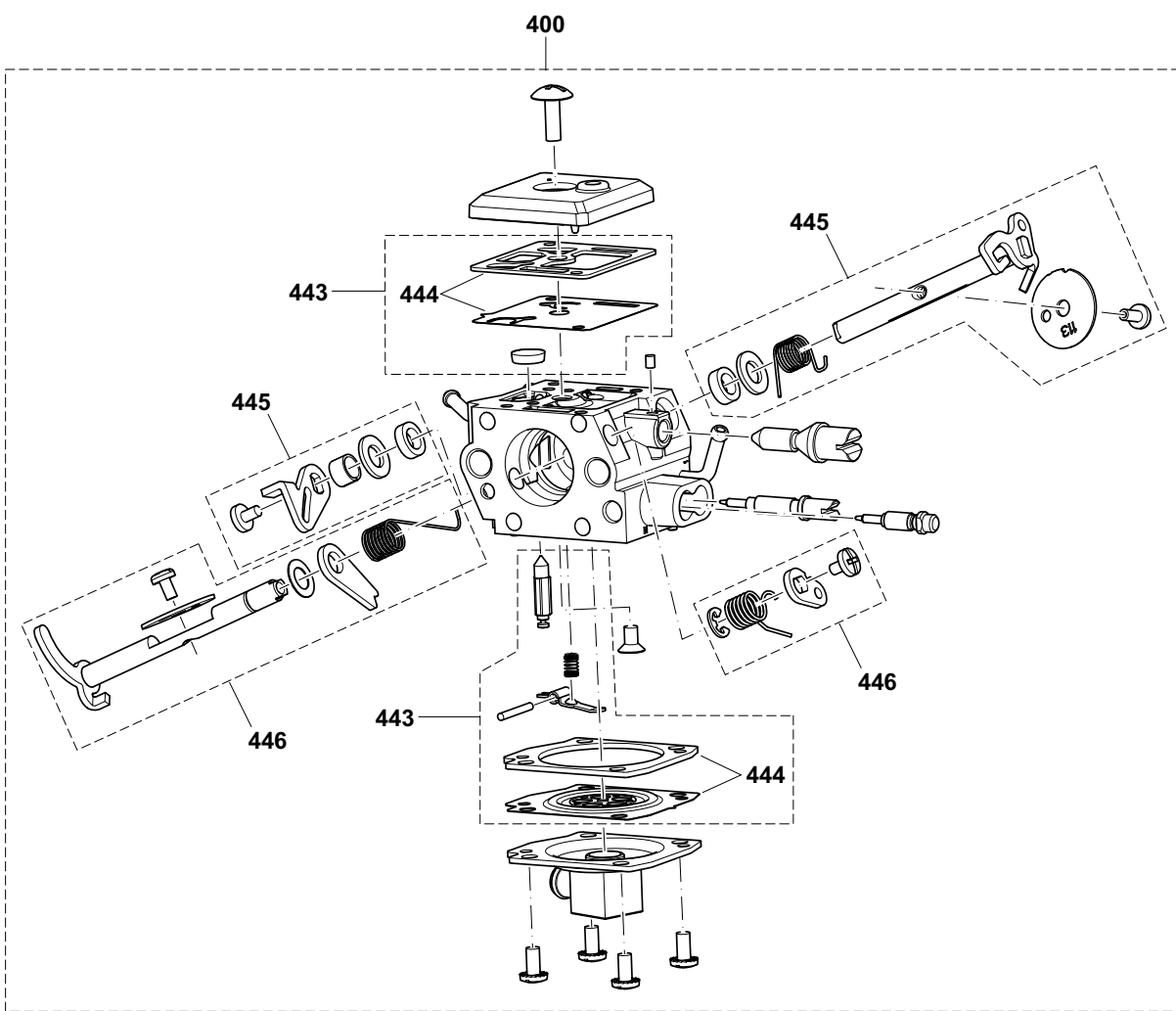
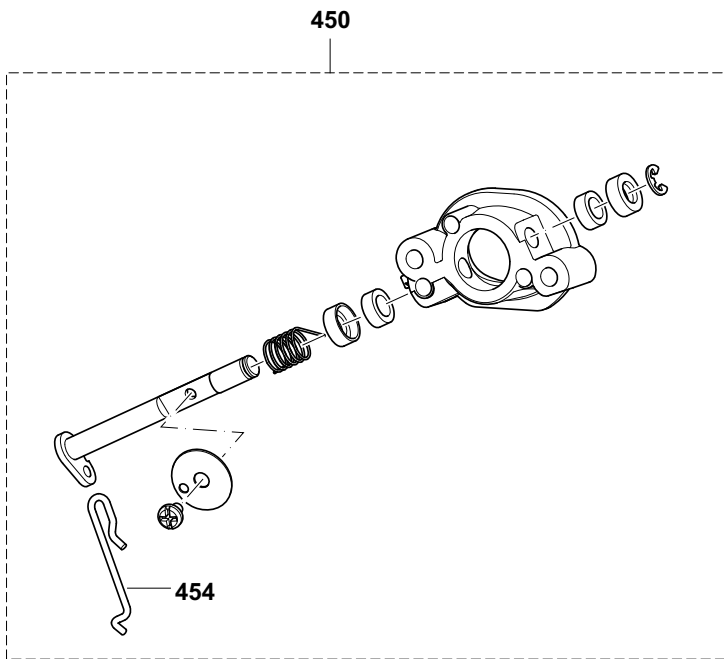

PC-6112, PC-6114

4

Vergaser
Carburetor
Carburateur
Carburador**DOLMAR**A member of the **Takita** Group

Seite / Page	Pos.	PC-6112	PC-6114	Teil-Nr. Part No. No. de pièce No. de pieza	Hinweise Notes Renseign. Nota	Bezeichnung	Spezifikation Specification	Description	Désignation	Denominación
4	400	1	1	315 153 100		VERGASER KPL.	DD - EU, US (regulated market)	CARBURETOR CPL.	CARBURATEUR CPL.	CARBURADOR CPL.
4	400	1	1	315 153 200		VERGASER KPL.	(non regulated market)	CARBURETOR CPL.	CARBURATEUR CPL.	CARBURADOR CPL.
4	443	1	1	315 153 680		REPARATURSATZ VERGASER		REPAIR KIT	JEU DE RÉPARATION	JUEGO DE REPARAR
4	444	1	1	315 153 690		DICHTUNG & MEMBRAN SATZ		GASKET & DIAPHRAGM KIT	JEU DE JOINT & MEMBRANE	JUEGA JUNTA & MEMBRANA
4	445	1	1	315 153 630		REP.-SATZ CHOKEWELLE		CHOKE KIT	JEU AXE CLAPET D'AIR	JUEGO EJE VÁLVULA AIRE
4	446	1	1	315 153 640		REP.-SATZ DROSSELWELLE		THROTTLE KIT	JEU AXE CLAPET D'ÉTRANG.	JUEGO EJE VÁLVULA REG.
4	450	1	1	315 153 700		LUFTKLAPPE KPL.		AIR FLAP CPL.	VOLET D'AÉRATION	VÁLVULA DE AIRE
4	454	1	1	315 153 740		KOPPELSTANGE		LINKAGE	TRINGLE	VARILLA

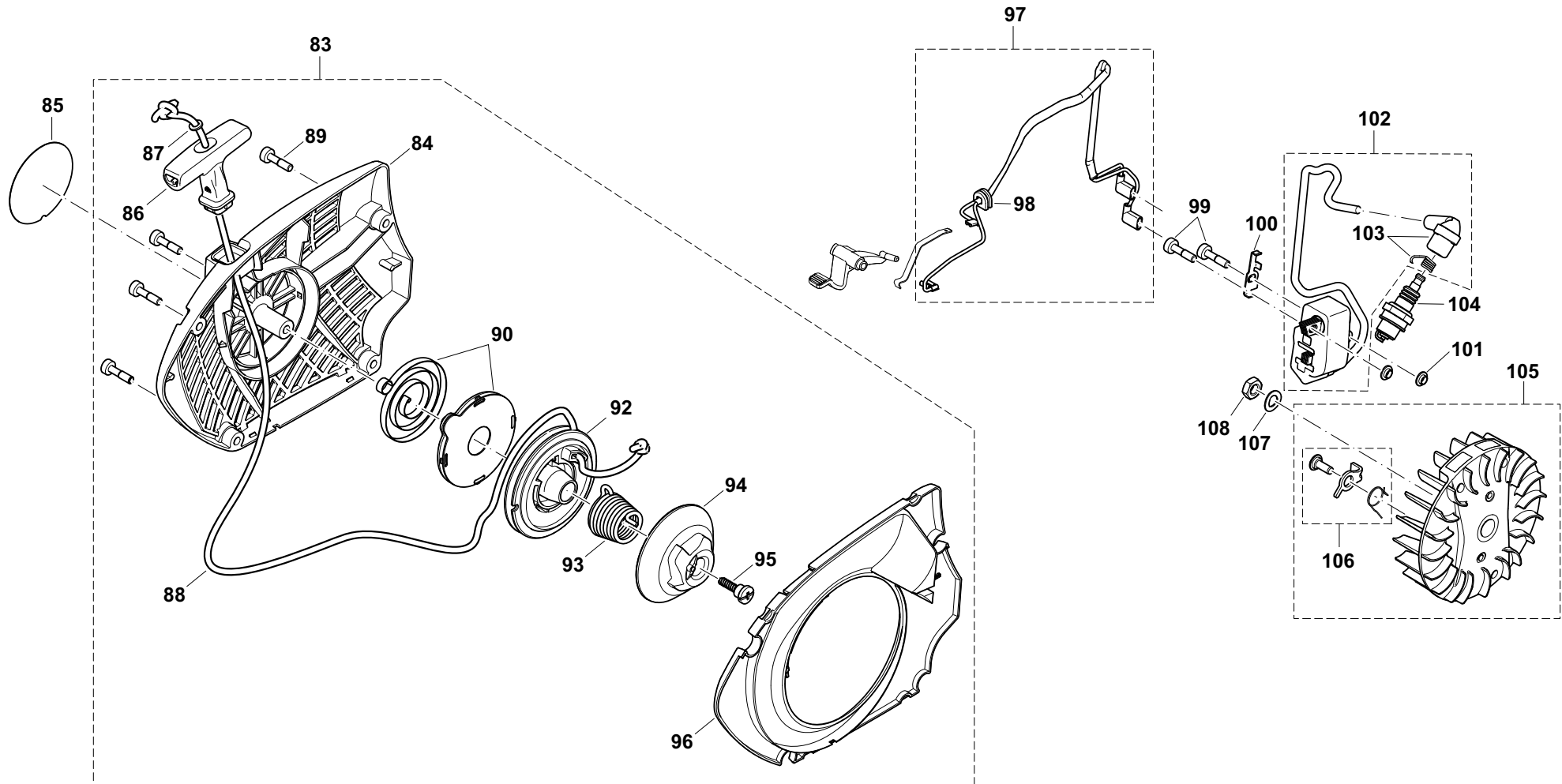

PC-6112, PC-6114

5

Anwerfvorrichtung, Magnetzünd
 Starter assy., ignition assy.
 Dispositif de démarrage, volant magnétique
 Dispositivo arranque, volante magnético

DOLMAR

 A member of the **Takita** Group

Seite / Page	Pos.	PC-6112	PC-6114	Teil-Nr. Part No. No. de pièce No. de pieza	Hinweise Notes Renseign. Nota	Bezeichnung	Spezifikation Specification	Description	Désignation	Denominación
5	83	1	1	315 160 100		ANWERFVORRICHTUNG ROT KPL.		STARTER ASSY. RED	DISPOS. DE DÉMARRAGE CPL.	DISPOS. DE ARRANQUE CPL. ROJO
5	84	1	1	315 160 030		STARTERGEHÄUSE ROT KPL.		STARTER ASSY. RED	DISPOS. DE DÉMARRAGE CPL.	DISPOS. DE ARRANQUE CPL. ROJO
5	85	1	1	980 115 513		SCHILD	DOLMAR	LABEL	PLAQUE	CALCOMANIA
5	86	1	1	181 164 010		ANWERFGRIFF		STARTER KNOB	POIGNEE DE LANCEMENT	TIRADOR DE ARRANQUE
5	87	1	1	928 405 000		SPANNSCHEIBE		DISC	DISQUE	ARANDELA
5	88	1	1	394 164 020		ANWERFSEIL SCHWARZ	ø4 x 1000mm	STARTER ROPE BLACK	CÂBLE DE DÉMARRAGE NOIR	CORDÓN DE ARRANQUE NEGRO
5	89	4	4	908 605 205		SCHRAUBE INNEN6RD	M5x20	SCREW	VIS	TORNILLO
5	90	1	1	181 163 050		RÜCKHOLFEDER IM GEHÄUSE		REWIND SPRING IN HOUSING	RESSORT RAPPEL DANS BOÎT	RESORTE RETENC. EN CAJA
5	92	1	1	315 162 020		SEILTROMMEL		CABLE DRUM	TAMBOUR DE CÂBLE	TAMBOUR PARA CORDÓN
5	93	1	1	181 163 080		FEDER FÜR LEICHTSTART		SPRING EASY-START	RESSORT DE RAPPEL	RESORTE RETENCIÓN
5	94	1	1	315 163 090		MITNEHMER		STARTER WHEEL	ROUE DÉCLENCHER	RUEDA DE ARRANQUE
5	95	1	1	181 163 095		SCHRAUBE		SCREW	VIS	TORNILLO
5	96	1	1	315 160 020		LUFTFÜHRUNG		AIR GUIDE PLATE	GUIDE D' AIR	CONDUCTO DE AIRE
5	97	1	1	315 147 010		KURZSCHLUSSKABEL		SHORT-CIRCUIT CABLE	CÂBLE D' ALLUMAGE	CABLE CORTO-CIRC.
5	98	1	1	965 401 016		GUMMITÜLLE		RUBBER BUSH	GAINE CAOUTCHOUC	BOQUILLA DE CAUCHO
5	99	2	2	908 805 205		ZYLINDERSCHRAUBE MIT SPANNSCHEIBE	M5X20	SCREW	VIS	TORNILLO
5	100	1	1	315 143 110		MASSEBLECH		EARTH SHEET	FIL DE MASSE	CONDUCCIÓN A MASA
5	101	2	2	195 143 031		ISOLIERSCHEIBE	nature	ISOLATING WASHER	RONDELLE	ARANDELA
5	102	1	1	315 143 100		ZÜNDSPULE KPL.		IGNITION COIL, CPL.	BOBINE D'ALLUMAGE CPL.	BOBINA DE ENCENDIDO CPL.
5	103	1	1	957 604 260		ZÜNDKERZENSTECKER KPL.		SPARK PLUG CAP CPL.	FICHE DE BOUGIE, CPL.	TAPA DE BUJIA CPL.
5	104	1	1	965 603 021		ZÜNDKERZE		SPARK PLUG	BOUGIE	BUJÍA
5	105	1	1	315 141 100		POLRAD KPL.		FLYWHEEL ASSY.	ROUE POLAIRE CPL.	VOLANTE ENCENDIDO
5	106	2	2	315 166 020		ANWERFKLINKE KPL.		STARTER RATCHET CPL.	CLIQUET CPL.	TRINQUETE ARRANQUE CPL.
5	107	1	1	926 208 001		FEDERSCHEIBE	B8	SPRING WASHER	RONDELLE ÉLASTIQUE	DISCO AMORTIGUADOR
5	108	1	1	920 308 024		6KT-MUTTER	M8x1	HEXAGONAL NUT	ECROU HEXAGONAL	TUERCA HEXAGONAL

PC-6112, PC-6114

6

Zylinder, Kurbeltrieb, Kupplung
Cylinder, crankshaft, clutch
Cylindre, vilebrequin, embrayage
Cilindro, cigüeñal, embrague

DOLMAR
A member of the *Trakita* Group

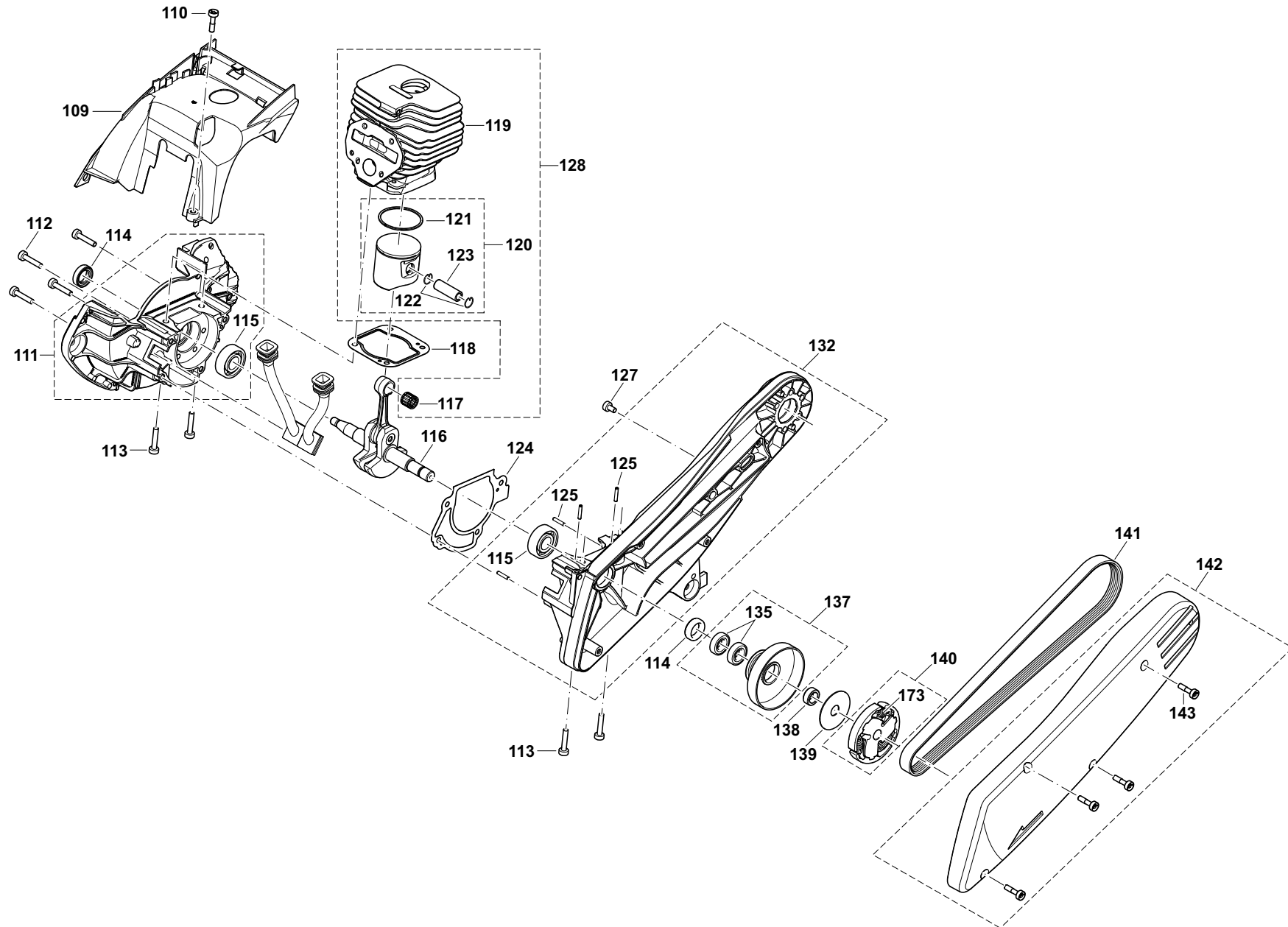

PC-6112, PC-6114

6

Zylinder, Kurbeltrieb, Kupplung
Cylinder, crankshaft, clutch
Cylindre, vilebrequin, embrayage
Cilindro, cigüeñal, embrague

DOLMAR
A member of the **Takita** Group

Seite / Page	Pos.	PC-6112	PC-6114	Teil-Nr. Part No. No. de pièce No. de pieza	Hinweise Notes Renseign. Nota	Bezeichnung	Spezifikation Specification	Description	Désignation	Denominación
6	109	1	1	315 131 110		KÜHLLUFTHAUBE		COOLING HOOD	CAPOT	CUBIERTA
6	110	1	1	908 605 205		SCHRAUBE INNEN6RD	M5x20	SCREW	VIS	TORNILLO
6	111	1	1	315 111 110		KURBELGEHÄUSE MS KPL.		CRANKCASE MAGN. SIDE ASSY.	CARTER-COTÉ MA. CPL.	CÁRTER CIG. LADO MA. CPL.
6	112	4	4	908 005 255		ZYLINDERSCHRAUBE	M5x25	PAN HEAD ALLEN SCREW	VIS CYLINDRIQUE	TORNILLO CILINDRICO
6	113	4	4	908 005 255		ZYLINDERSCHRAUBE	M5x25	PAN HEAD ALLEN SCREW	VIS CYLINDRIQUE	TORNILLO CILINDRICO
6	114	2	2	962 900 052		RADIALDICHTUNG	ø15/24x7	RADIAL RING	JOINT RADIAL	JUNTA RADIAL
6	115	2	2	960 102 159		KUGELLAGER (EINKLEBEN)	6202	BALL BEARING (USE GLUE)	ROULEMENT À BILLES (À COLLER)	RODAM. DE BOLAS (A COLAR)
6	116	1	1	315 120 010		KURBELWELLE KPL.		CRANKSHAFT ASS'Y	VILEBREQUIN CPL.	CIGÜEÑAL CPL.
6	117	1	1	962 210 111		NADELKRANZ		NEEDLE CAGE	CAGE À AIGUILLES	JAULA DE AGUJAS
6	118	1	1	315 131 020		ZYLINDERFUßDICHTUNG		GASKET	JOINT	JUNTA
6	119	1	1	315 131 010		ZYLINDER	D47	CYLINDER	CYLINDRE	CILINDRO
6	120	1	1	315 132 101		KOLBEN KPL.	D47	PISTON CPL.	PISTON CPL.	PISTÓN CPL.
6	121	1	1	315 132 020		KOLBENRING	D47	PISTON RING	SEGMENT DE PISTON	SEGMENT DE PISTON
6	122	2	2	315 132 040		SPRENGRING	11	CIRCLIP	ANNEAU RESSORT	ANILLO ELÁSTICO
6	123	1	1	315 132 050		KOLBENBOLZEN		PISTON PIN	AXE DE PISTON	BULÓN DEL PISTÓN
6	124	1	1	315 111 030		KURBELGEHÄUSEDICHTUNG		CRANK CASE GASKET	JOINT	JUNTA
6	125	4	4	936 430 160		SPIRALSPANNSTIFT	3X16	CLAMPING PIN	GOUPILLE	PASADOR
6	127	1	1	908 005 095		SCHRAUBE	M5x9	SCREW	VIS	TORNILLO
6	128	1	1	957 130 315		ZYLINDER / KOLBEN KPL.	D47	CYLINDER / PISTON CPL.	CYLINDRE ET PISTON CPL.	CILINDRO CON PISTÓN CPL.
6	132	1	1	315 111 130		KURBELGEHÄUSE KS KPL.	300 (12")	CRANKCASE CL. SIDE ASSY.	CARTER-COTÉ EM. CPL.	CÁRTER CIG. LADO EM. CPL.
6	132	1	1	315 111 230		KURBELGEHÄUSE KS KPL.	350 (14")	CRANKCASE CL. SIDE ASSY.	CARTER-COTÉ EM. CPL.	CÁRTER CIG. LADO EM. CPL.
6	135	2	2	960 124 126		KUGELLAGER	6901	BALL BEARING	ROULEMENT À BILLES	RODAMIENTO DE BOLAS
6	137	1	1	315 223 020		KUPPLUNGSTROMMEL KPL.		CLUTCH DRUM CPL.	TAMBOUR CPL.	TAMBOR CPL.
6	138	1	1	315 183 010		DISTANZHÜLSE		SPACER	DOUILLE DE DISTANCE	CASQUILLO SEPARADOR
6	139	1	1	001 182 042		FÜHRUNGSSCHEIBE	44,5x1x12	DISC	DISQUE	DISCO
6	140	1	1	181 180 200		KUPPLUNG KPL.		CLUTCH ASSY.	EMBRAYAGE CPL.	EMBRAGUE CPL.
6	141	1	1	965 300 501		KEILRIPPENRIEMEN	6PJ716 (12")	V-BELT	COURROIE TRAPEZ	CORREA ESTRECHO
6	141	1	1	965 300 510		KEILRIPPENRIEMEN	6PJ812 (14")	V-BELT	COURROIE TRAPEZ	CORREA ESTRECHO
6	142	1	1	315 211 100		RIEMENABDECKUNG KPL.	DOLMAR (12")	BELT COVER ASS'Y	COUVERCLE DE COURROIE CPL.	CUBIERTA DE CORREA PL.
6	142	1	1	315 211 200		RIEMENABDECKUNG KPL.	DOLMAR (14")	BELT COVER ASS'Y	COUVERCLE DE COURROIE CPL.	CUBIERTA DE CORREA PL.
6	143	4	4	315 211 060		SCHRAUBE INNEN6RD ZK	M5x20	SCREW	VIS	TORNILLO
6	173	3	3	181 184 010		ZUGFEDER FÜR KUPPLUNG		SPRING	RESSORT	RESORTE

PC-6112, PC-6114

7

Schneidvorsatz, Schutzhaube
Cutting device, protection hood
Dispositif de coupe, capot de protection
Dispositivo tronzadora, cubierta protectora

DOLMAR
A member of the *Trakita* Group

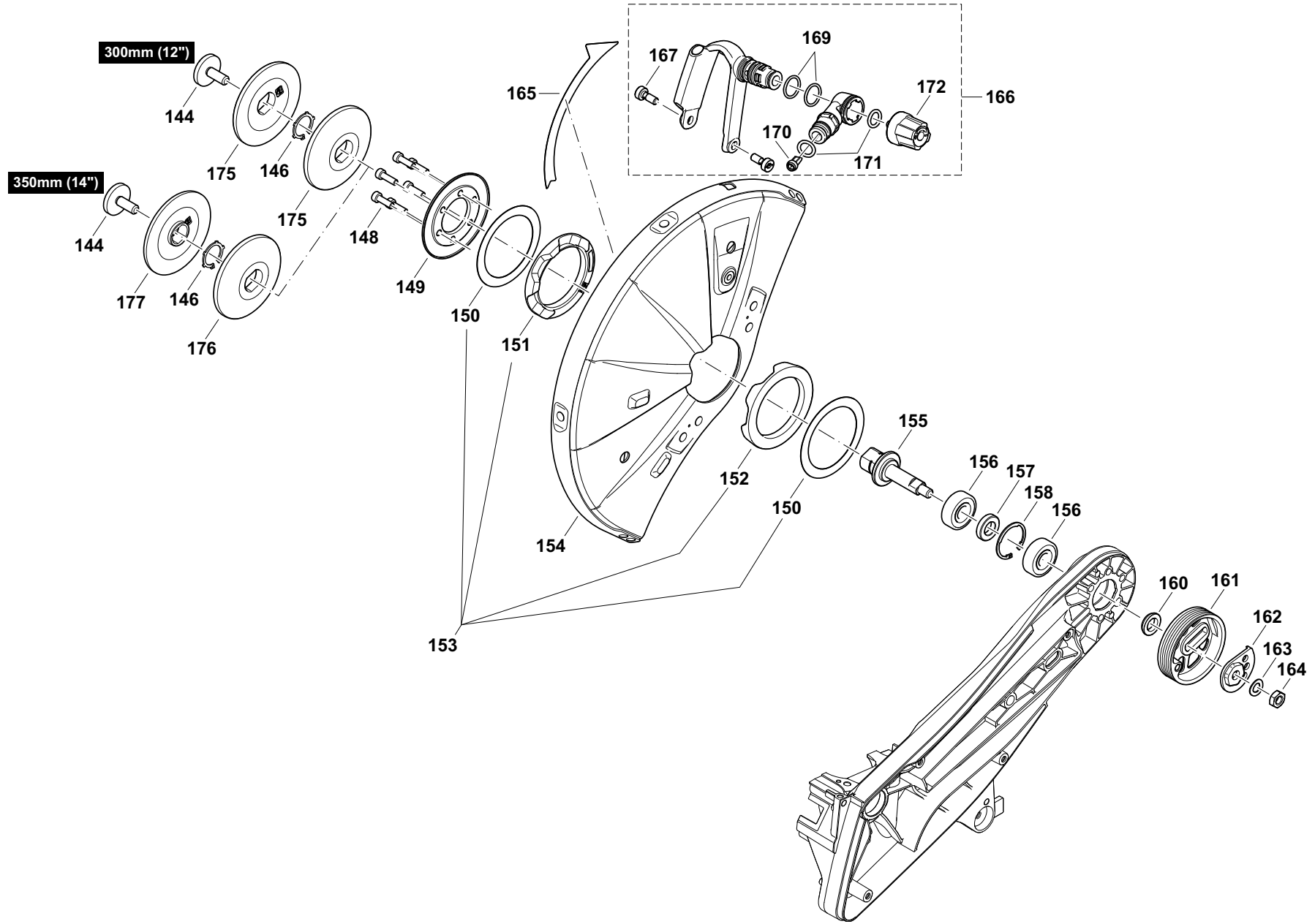

PC-6112, PC-6114

7

Schneidvorsatz, Schutzhaube
Cutting device, protection hood
Dispositif de coupe, capot de protection
Dispositivo tranzadora, cubierta protectora

DOLMAR
A member of the **Takita** Group

Seite / Page	Pos.	PC-6112	PC-6114	Teil-Nr. Part No. No. de pièce No. de pieza	Hinweise Notes Renseign. Nota	Bezeichnung	Spezifikation Specification	Description	Désignation	Denominación
7	144	1	1	994 290 250		6KT-SCHRAUBE	M8x25	HEXAGON HEAD BOLT	VIS À SIX PANS	TORNILLO HEXAGONAL
7	146	1	1	929 420 120		SICHERUNGSRING	20X1,2	RETAINING RING	CIRCLIP	ANILLO SEGURIDAD
7	148	6	6	908 405 145		SCHRAUBE	M5x14	SCREW	VIS	TORNILLO
7	149	1	1	315 342 010		DRUCKRING		PRESSURE RING	BAGUE DE PRESSION	ANILLO DE PRESIÓN
7	150	2	2	315 342 030		GLEITSCHEIBE		SLIDING DISC	DISQUE DE GLISSEMENT	ARANDELA DESLIZANTE
7	151	1	1	315 342 050		GUMMIRING INNEN		RUBBER RING INT.	BAGUE EN CAOUTCHOUC INT.	ANILLO DE GOMA INTERIOR
7	152	1	1	315 342 040		GUMMIRING AUßEN		RUBBER RING EXT.	BAGUE EN CAOUTCHOUC EXT.	ANILLO DE GOMA EXTERIOR
7	153	1	1	957 342 030		AUFNAHME SCHUTZHAUBE KPL.		PROT. HOOD MOUNTING, CPL.	LOGEMENT CAPOT DE PROT. CPL.	ALOJAMIENTO CUB. PROT., CPL.
7	154	1	1	315 341 050		SCHUTZHAUBE KPL.	300cm/12"	PROTECTION HOOD ASSY.	CAPOT DE PROTECTION CPL.	CUBIERTA PROTECTORA CPL.
7	154	1	1	315 341 200		SCHUTZHAUBE KPL.	350cm/14"	PROTECTION HOOD ASSY.	CAPOT DE PROTECTION CPL.	CUBIERTA PROTECTORA CPL.
7	155	1	1	315 228 030		ACHSE	20,0	AXLE	AXE	EJE
7	156	2	2	960 102 126		KUGELLAGER	6201 LLU	BALL BEARING	ROULEMENT À BILLES	RODAMIENTO DE BOLAS
7	157	1	1	315 228 021		DISTANZHÜLSE		SPACER	DOUILLE DE DISTANCE	CASQUILLO SEPARADOR
7	158	1	1	929 232 120		SPRENGRING	32X1,2	RETAINING RING	ANNEAU RESSORT	ANILLO ELÁSTICO
7	160	1	1	315 221 040		SCHEIBE		WASHER	RONDELLE	ARANDELA
7	161	1	1	315 221 021		KEILRIPPENSCHLEIBE	12"	BELT PULLEY	POULIE	POLEA
7	161	1	1	315 221 120		KEILRIPPENSCHLEIBE	14"	BELT PULLEY	POULIE	POLEA
7	162	1	1	315 221 030		EXZENTER		ECCENTRIC	EXCENTRIQUE	EXCÉNTRICA
7	163	1	1	926 208 001		FEDERSCHLEIBE	B8	SPRING WASHER	RONDELLE ÉLASTIQUE	DISCO AMORTIGUADOR
7	164	1	1	920 308 024		6KT-MUTTER	M8x1	HEXAGONAL NUT	ECROU HEXAGONAL	TUERCA HEXAGONAL
7	165	1	1	980 115 666		SICHERHEITSAUFKLEBER	300/20/80	CAUTION LABEL	PLAQUE	CALCOMANIA
7	165	1	1	980 115 768		SICHERHEITSAUFKLEBER	300/20/80 (RU)	CAUTION LABEL	PLAQUE	CALCOMANIA
7	165	1	1	980 115 769		SICHERHEITSAUFKLEBER	350/25,4/80	CAUTION LABEL	PLAQUE	CALCOMANIA
7	165	1	1	980 115 770		SICHERHEITSAUFKLEBER	350/20/80	CAUTION LABEL	PLAQUE	CALCOMANIA
7	165	1	1	980 115 771		SICHERHEITSAUFKLEBER	350/25,4/80 (RU)	CAUTION LABEL	PLAQUE	CALCOMANIA
7	165	1	1	980 115 772		SICHERHEITSAUFKLEBER	350/20/80 (RU)	CAUTION LABEL	PLAQUE	CALCOMANIA
7	166	1	1	957 341 040		WASSERSET KPL.		WATER ATTACHMENT KIT	JEU DE RACCORDEMENT DE L'EAU	ACOMETIDA DE AGUA
7	167	2	2	315 341 140		DÜSENSCHRAUBE		JET SCREW	VIS	TORNILLO
7	169	2	2	963 216 020		O-RING	16x2	O-RING	JOINT TORIQUE	ANILLO DE GUARNICIÓN
7	170	1	1	315 341 150		WASSERFILTER		WATER SUCTION FILTER	FILTRE	FILTRO
7	171	2	2	963 211 025		O-RING	11X2,5	O-RING	JOINT TORIQUE	ANILLO DE GUARNICIÓN
7	172	1	1	315 341 130		REGULIERSCHRAUBE		REGULATING SCREW	VIS DE REGLAGE	TORNILLO REGULADOR
7	175	2	2	315 228 011		SPANNFLANSCH	20,0 (300cm/12")	PRESSURE DISC	DISQUE DE PRESSION	DISCO DE PRESIÓN
7	176	1	1	315 228 110		SPANNFLANSCH	20,0 (350cm/14")	PRESSURE DISC	DISQUE DE PRESSION	DISCO DE PRESIÓN
7	177	1	1	315 228 110		SPANNFLANSCH	20,0 (350cm/14")	PRESSURE DISC	DISQUE DE PRESSION	DISCO DE PRESIÓN
7	177	1	1	315 228 120		SPANNFLANSCH	25,4 (350cm/14")	PRESSURE DISC	DISQUE DE PRESSION	DISCO DE PRESIÓN

PC-6112, PC-6114

8

Trennscheiben, Werkzeug
Blades, tools
Disques, outils
Discos para dividir, herramientas

DOLMAR
A member of the **Trakita** Group

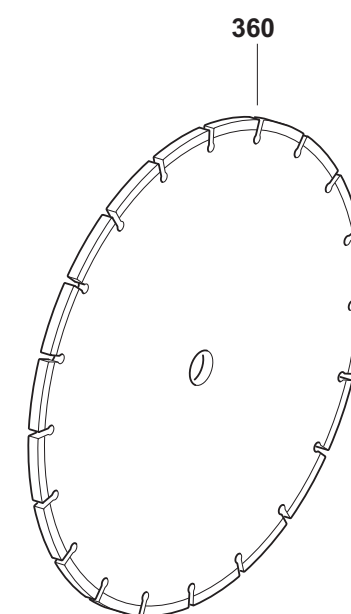
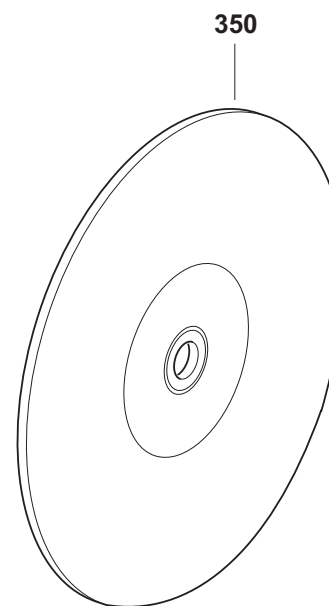
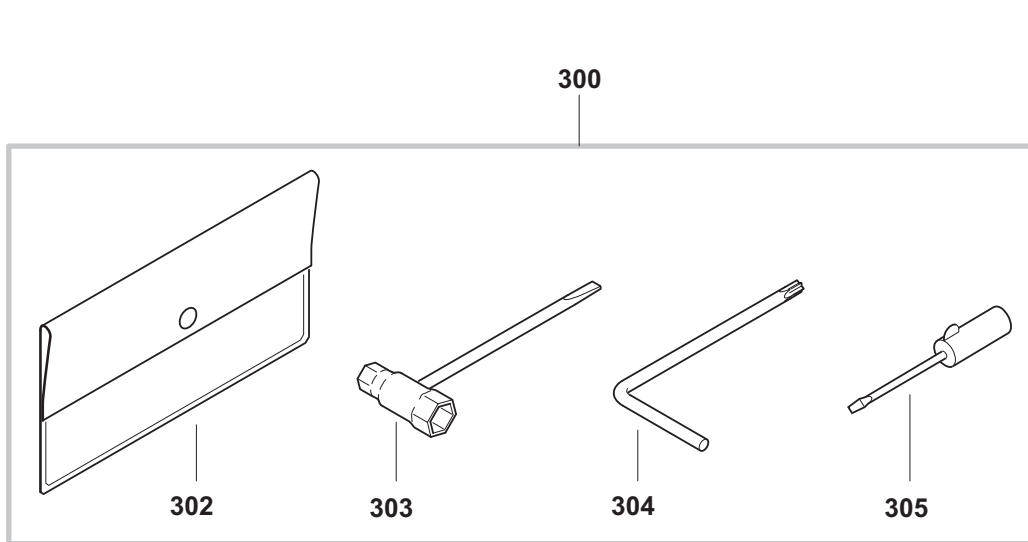

PC-6112, PC-6114

8

Trennscheiben, Werkzeug
Blades, tools
Disques, outils
Discos para dividir, herramientas

DOLMARA member of the **Makita** Group

Seite / Page	Pos.	PC-6112	PC-6114	Teil-Nr. Part No. No. de pièce No. de pieza	Hinweise Notes Renseign. Nota	Bezeichnung	Spezifikation Specification	Description	Désignation	Denominación
8	300	1	1	957 004 002		WERKZEUG KPL.		TOOL CPL.	OUTILS CPL.	HERRAMIENTAS CPL.
8	302	1	1	950 004 002		WERKZEUGTASCHE		PLASTIK BAG	POCHETTE EN PLASTIQUE	CÁRTERA HERRAMIENTAS
8	303	1	1	941 719 131		KOMBISCHLÜSSEL	SW 13/19 mm	UNIVERSAL WRENCH	CLÉ COMBINÉE	LLAVE DE BUJIA
8	304	1	1	940 827 000		WINKELSCHRAUBENDREHER	T27	ANGLED SCREW DRIVER	CLÉ ANGLE	LLAVE ANGULAR
8	305	1	1	944 340 001		SCHRAUBENDREHER		SCREWDRIVER	TOURNEVIS	DESTORNILLADOR
8	350	1				TRENNSCHEIBE KUNSTHARZ	ø 300mm/12"	BLADE SYNTHETIC	DISQUE SYNTHÉTIQUE	DISCO SINTÉTICO
8	350		1			TRENNSCHEIBE KUNSTHARZ	ø 350mm/14"	BLADE SYNTHETIC	DISQUE SYNTHÉTIQUE	DISCO SINTÉTICO
8	360	1				TRENNSCHEIBE DIAMANT	ø 300mm/12"	DIAMOND BLADE	DISQUE DIAMANT	DISCO DIAMANTE
8	360		1			TRENNSCHEIBE DIAMANT	ø 350mm/14"	DIAMOND BLADE	DISQUE DIAMANT	DISCO DIAMANTE

PC-6112, PC-6114

DOLMAR



A member of the **Takita** Group

	Zeichenerklärung	Key to symbols	Légende	Explicación de símbolos
=> 1999999 2000000 => 2003.04 => TI 2003/07 Acc. = { m Corr.	Produktion bis Serien-Nr. Neues Teil ab Serien-Nr. Neues Teil ab Jahr / Monat Siehe Technische Information Jahr / Nr. Zubehör (nicht im Lieferumfang) Keine Serienausführung, jedoch verwendbar Beinhaltet Positions-Nr. Meterware Druckfehlerberichtigung	Production to serial number New part from serial number New part from Year / Month See Technical Information Year / No. Accessories (not included in the delivery inventory) No standard execution, may be used Contains item number Sold by the meter Error correction	Production jusqu'à n° de série Nouvelle pièce à partir du n° de série Nouvelle pièce à partir de année / mois Voir information technique année / n° Accessoires (non compris dans la livraison) Aucune exécut. en série, cependant utilisable contient n° de numéro Au mètre Rectification d'erreurs	Producción hasta N° de serie Pieza nueva a partir de N° de serie Pieza nueva a partir de año / mes Véase inform. técnico año / N° Accesorios (no incluido en la extensión del suministro) No es de serie, pero sirve Contiene pos N° Por metro Fe de erratas
	Änderungen vorbehalten	Specifications subject to change without notice	Changements sans préavis	Mejoras constructivas sin previo aviso